

ENSIM

Measuring Excellence

PROCESS CONTROL
SENSORS

SENSORS

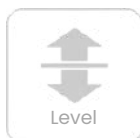

ABOUT US

LONCA A.Ş. is one of the leading companies of Turkey in measurement-control devices since 1984. Lonca has been providing wide range of products under brand "Ensim Sensors" while also importing other type of models to meet requirements of automation sector.

LONCA A.Ş. always driven with the spirit of innovation and a passion for a contribution to make industry easier everyday. While our production capacity is growing , LONCA A.Ş. adds different quality certifications such as: ATEX, ISO 9001, ISO 27001, ISO 50001, ISO 10002, ISO 22301, ISO 45001, ISO 14001, ISO 80079-34 under it's organization every year.

Ensim Sensors product portfolio offers wide range of options in measurement instruments including Level , Flow , Pressure , Temperature sensors , Calibration Bath and Control Equipment.



PRODUCT

LEVEL

Capacitive Type Level Switch
Capacitive Type Level Transmitter
OEM Capacitive Type Level Sensor
Float Type Level Switch
Float Type Level Transmitter
Side Mounting Type Level Switch
By-Pass Magnetic Level Gauge
Reflex Type Level Gauge
Rotary Paddle Level Switch
Vibrating Rod Type Level Switch
Float Type Mini Level Switch – Metal Version
Float Type Mini Level Switch – Plastic Version
Conductivity Type Level Switch
Water , Oil , Acid Warning Dedector
Radar Type Level Transmitter
Membrane Type Level Switch
Tilt Switch
Cable Level Switch
Float Valve
Sight Level Indicator

FLOW

Flow Switch
Flow Indicator
Flow Measurement with Orifice
E / M Flowmeter
Pitot Tube

PRESSURE

Pressure Switch
Differential Pressure Switch
Differential Pressure Gauge
Cooling Apparatus

TEMPERATURE

Temperature Transmitter
Temperature Sensor
Thermowell

CONTROL

GSM / GPRS / Wi-fi / RF Control
ModBus I/O Module
USB-RS 485 Converter
GSM-GPRS Modem
Tank Filling System

CALIBRATION

Dry-Well Calibrator
Calibration Bath

ANALYSIS

PH Measurement
ORP Measurement

CERTIFICATES

BRAND NAME

T.C. TÜRK PATENT VE MARKA KURUMU
MARKA TESCİL BELGESİ
 Marka No : 1418 2994 - Tüket - Hizmet

ENSiM SENSORS

Marka Sahibi : LONCA MAKİNA SAN. VE TİC. A.Ş. İZMİR
 İletişim : 0232 399 137
 İhale Tarihi : 18.09.2018

İhale Marka 26/03/2018 tarihindeki ihalede ON VİL şirket 05/09/2018 tarihinde satın almıştır.

TURK PATENT

ISO 9001 : 2015

Bureau Veritas Certification

LONCA MAKİNA SAN. VE TİC. A.Ş.
 FERTİHTAŞA MAK. GAZIPAŞA CAD. NO:104 A ATAŞEHİR İSTANBUL, TÜRKİYE

ISO 9001:2015
 Design, Production, Sales and After Sales Services of Measurement and Control Instruments (Ölçü ve Kontrol Aletleri Tasarımı, Üretimi, Satış ve Satış Sonrası Hizmetleri)

Validity Date : 12.08.2021

ISO 14001: 2015

Registered CCPL

Registration Certificate
 The Management System of
LONCA MAKİNA SAN. TİC. A.Ş.
 Carried out as following site:
 Fertahpaşa Mahallesi, Gazipaşa Caddesi, No:104 A PK:34888 Ataşehir İSTANBUL/TÜRKİYE

ISO 14001:2015
 Design, Production, Sales and After Sales Services of Measurement and Control Instruments (Ölçü ve Kontrol Aletleri Tasarımı, Üretimi, Satış ve Satış Sonrası Hizmetleri)

Validity Date : 18.09.2018

ISO 45001 : 2018

Registered CCPL

Registration Certificate
 The Management System of
LONCA MAKİNA SAN. TİC. A.Ş.
 Carried out as following site:
 Fertahpaşa Mahallesi, Gazipaşa Caddesi, No:104 A PK: 34888 Ataşehir İSTANBUL/TÜRKİYE

ISO 45001:2018
 Design, Production, Sales and After Sales Services of Measurement and Control Instruments (Ölçü ve Kontrol Aletleri Tasarımı, Üretimi, Satış ve Satış Sonrası Hizmetleri)

Validity Date : 18/09/2018

ISO 27001: 2013

EAS

Compliance Certificate
 The Management System of
LONCA MAKİNA SAN. TİC. A.Ş.
 Carried out as following site:
 Fertahpaşa Mahallesi, Gazipaşa Caddesi, No:104 A PK: 34888 Ataşehir İSTANBUL/TÜRKİYE

ISO 27001:2013
 Design, Production, Sales and After Sales Services of Measurement and Control Instruments (Ölçü ve Kontrol Aletleri Tasarımı, Üretimi, Satış ve Satış Sonrası Hizmetleri)

Validity Date : 12.08.2021

ISO 10002 : 2018

EAS

Registration Certificate
 The Management System of
LONCA MAKİNA SAN. TİC. A.Ş.
 Carried out as following site:
 Fertahpaşa Mahallesi, Gazipaşa Caddesi, No:104 A PK: 34888 Ataşehir İSTANBUL/TÜRKİYE

ISO 10002:2018
 Design, Production, Sales and After Sales Services of Measurement and Control Instruments (Ölçü ve Kontrol Aletleri Tasarımı, Üretimi, Satış ve Satış Sonrası Hizmetleri)

Validity Date : 18/09/2018

ISO 45001 : 2018

EAS

Registration Certificate
 The Management System of
LONCA MAKİNA SAN. TİC. A.Ş.
 Carried out as following site:
 Fertahpaşa Mahallesi, Gazipaşa Caddesi, No:104 A PK: 34888 Ataşehir İSTANBUL/TÜRKİYE

ISO 45001:2018
 Design, Production, Sales and After Sales Services of Measurement and Control Instruments (Ölçü ve Kontrol Aletleri Tasarımı, Üretimi, Satış ve Satış Sonrası Hizmetleri)

Validity Date : 18/09/2018

ISO 27001: 2013

EAS

Compliance Certificate
 The Management System of
LONCA MAKİNA SAN. TİC. A.Ş.
 Carried out as following site:
 Fertahpaşa Mahallesi, Gazipaşa Caddesi, No:104 A PK: 34888 Ataşehir İSTANBUL/TÜRKİYE

ISO 22301 : 2019
 Design, Production, Sales and After Sales Services of Measurement and Control Instruments (Ölçü ve Kontrol Aletleri Tasarımı, Üretimi, Satış ve Satış Sonrası Hizmetleri)

Validity Date : 18/09/2025

EN ISO 3834-2

TUV AUSTRIA

CERTIFICATE
 The certification body of TÜV AUSTRIA SERVICES GmbH certifies that
LONCA MAKİNA SAN. TİC. A.Ş.
 FERTİHTAŞA MAHALLESİ, GAZIPAŞA CADDESİ, NO: 144 A PK: 34888 ATAŞEHİR, İSTANBUL, TÜRKİYE

has met all necessary quality requirements for welding according to
EN ISO 3834-2

Validity Date : 11.06.2022

CERTIFICATES

10204-3.1 INSPECTION CERTIFICATE

 Lonca MAK.SAN.TIC.A.Ş.	MUAYENE SERTİFİKASI INSPECTION CERTIFICATE ABNAHMEPRÜFZEUGNIS (LPM102)						
Ferhatpaşa Mah. Gazipaşa Cad. No: 104 / A ZİP:34888 Ataşehir / İstanbul/TÜRKİYE Tel : +90 216 50 50 555 (gsm) Faks : +90 216 515 43 61 Mobil : +90 533 777 99 95 E-Posta : lonca@ensim.com.tr Web : www.ensim.com.tr		According to / nach EN 10204-3.1					
ALICI FIRMA / PURCHASER COMPANY / KUNDE UNTERNEHMEN İMALİYE TARİHİ / DELIVERY DATE / LIEFERUNGS DATUM İMALİYE NUMARASI / DELIVERY NO / LIEFERUNGS NUMBER SIPARIŞ NUMARASI / ORDER NO / BESTELLUNG NO SERTİFİKA NUMARASI / CERTIFICATE NO / ZERTIFIKAT NUMBER SERTİFİKA TARİHİ / CERTIFICATE DATE / ZERTIFIKAT DATUM SERTİFİKA STANDARTLARI / CERTIFICATE STANDARDS		TEST ŞARTLARI TEST CONDITIONS PRÜFBEINGUNGEN Bağırlık/Temporata/Temperatur: 25 °C Bağırlık Nem / Rel. Humidity / n. Luftfeuchtigkeit: 50 RH					
MAMUL / PRODUCT / PRODUKTE							
S.N. NO	ÜRÜN KODU PRODUCT CODE	ÜRÜN ADI PRODUCT NAME	ADET QUANTITY	SERİ NO SERIAL NUMBER			
128	ELG104-01-07-GP-000-800-T2-100P MAGNETIC LEVEL INDICATOR ELG104 40 BAR		4 AD	02000000-0001 02000000-0002 02000000-0003 02000000-0004			
MALZEME / MATERIAL / MATERIAL							
ÜRÜN ADI PRODUCT NAME	MALZEME ÇİNSİ TYPE OF MATERIAL	ANALİZ RAPORU ANALYSIS REPORT	SATIN ALMA ŞARTLARI PURCHASE CONDITIONS				
BORU 304 PAS ÇELİK Ø80,3x1mm	304 SS						
BORU 304 PAS ÇELİK Ø27x1mm	304 SS						
BAÇ 304 PAS ÇELİK PLAKA 0180mm	304 SS						
TESTLER / TESTS / TESTS							
SIRA NO	Test İsmi Test Name	Çihaz Kapasitesi/ Device Capacity/ Gerilim Kapasitesi	Kabul Kriteri/ Acceptance Criteria/ Annahmekriterien	Test Aralığı/ Test Range/ Test Bereich	Test Süresi/ Test Time/ Test Zeit	Kullanılan Alet/ Faulty Product Used/ Produktmenge	Sonuç / Result/ Prüfgergebnis
1	Çözüm Test / Visual	Gözlem Observation Beobachtung	Ürün Standart Product Standard Produktstandard	Tümü All the equipments Alle geräte	1 Dak 1 Min 1 Min	Yok No Nein	Uygun Approved Angenommen
2	Fonksiyon Test - Measur/ Functional Test - Measur/ Funktionsprüfung - Measur	Düzenli Observation Beobachtung	Ürün Standart All the Equipments Alle Geräte	Tümü All the equipments Alle geräte	1 Dak 1 Min 1 Min	Yok No Nein	Uygun Approved Angenommen
SONUÇ / RESULT / PRÜFERGEBNIS							
Testi Yapan / Prepared / Vorbereitet:		Tarih / Date / Datum:		#131.975			
Uygunluk / Usability / Untauglichkeit:							
Düzeltilmiş / Corrected / Korrekturmaßnahmen:							
Bu sertifikayı yukarıda bahsi geçen mamüllerin siparişi uygun olduğunu teyit eder. This certificate attests that the product described above complies with the lot more order contract. Dieses zertifikat beweist in der Riede stehende produkte dass sie für die bestellung geeignet ist.							
Hazırlayan / Prepared / Vorbereitet:		Kalite Güvencesi/Quality Assurance/Qualitätsicherung					
Dağıtım No : F.Kal.008		Tarih : 29.08.2019		Revizyon : 006		Bilen : KG	

STRATEGIC PLAN

2025-2027 STRATEJİK PLAN



INDUSTRIAL REGISTRY CERTIFICATE

	T.C. SANAYİ VE TEKNOLOJİ BAKANLIĞI SANAYİ GENEL MÜDÜRLÜĞÜ	SANAYİ SİCİL BELGESİ e-belge	
Belge Tarihi : 22/07/2023	Belge No : 524157	Vergi/TC No : 6090017337	
İşyeri İşletme Ünvanı : LONCA MAKİNA SANAYİ TİCARET ANONİM ŞİRKETİ			
İşyeri Adresi : FERHATPAŞA MAHALLESİGAZİPAŞACADDESİ NO: 104 A ATAŞEHİR/İSTANBUL			
Vize Tarihi : 22/07/2023	Vize Dönemi/Bilgi Tarihi : 22/07/2025	Üretim Konusu	
SICAKLIK TRANSMİTTERİ (.), AKIŞ SENSÖRÜ (.), SEVİYE GÖSTERGESİ (.), SEVİYE TRANSMİTTERİ (.), SU SEVİYE ŞALİTERİ (.), SEVİYE SENSÖRÜ (.), BASINÇ ŞALİTERİ (.), SICAKLIK SENSÖRÜ (.)			
Yukarıda belirtilen yazılı işletme 24.04.1957 tarih ve 5948 sayılı Kanunun ikinci maddesi gereğince tescil edilmiş olup 2041 sayılı Sefaralık ve Savaş Hukuk Kanunları gereğince Türk İşleri Kurumuna sığınmış ve bu kanunla tahsis edilmiş sayılır.			Belge Basım Tarihi : 01/08/2023
Bu belge düzenleme tarihi itibarıyla belge geçerli olup diğer belge geçerli olup-ili yıla bir vize etkilenecektir. Sanayi Sicil Belgesi 1/1 sayılıdır.			
İşbu e-belge İSTANBUL Sanayi ve Teknoloji İl Müdürlüğü tarafından düzenlenmiş olup belge geçerliliği doğrulamak için yukarıdaki QRCode veya eşya kodu ile kullanılabilir. https://sanajisicil.sanayi.gov.tr/#/belge/524157/6090017337/29082019			

SUSTAINABILITY REPORT



SYMBOLS

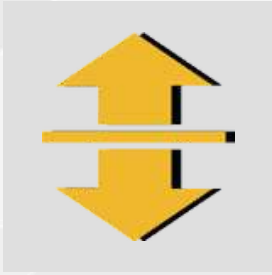

ATEX LEVEL

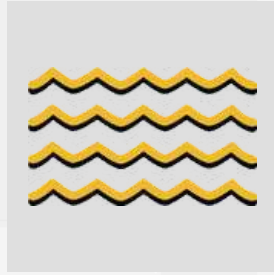

ATEX FLOW

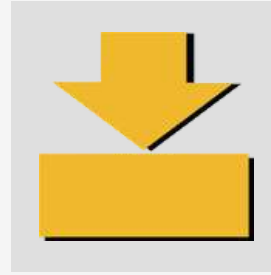

ATEX PRESSURE



ATEX TEMPERATURE

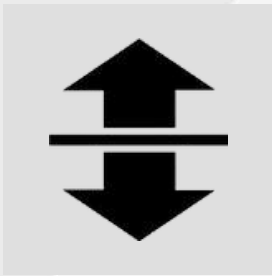

LEVEL

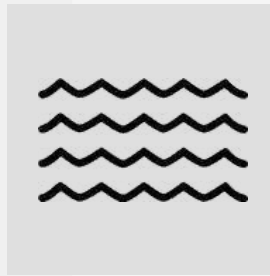

FLOW

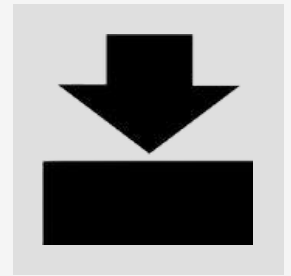

PRESSURE

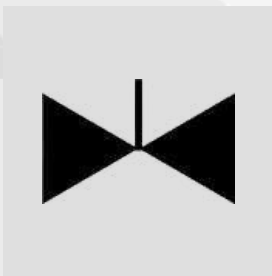

VALVE

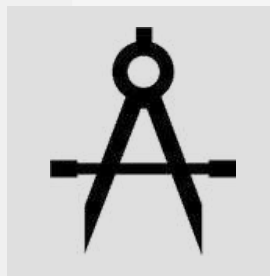

CALIBRATION

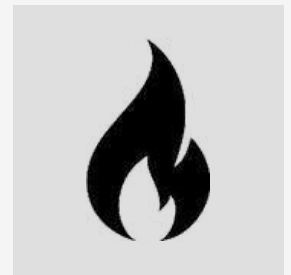

TEMPERATURE

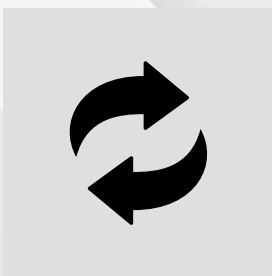

ANALYSIS & CONTROL

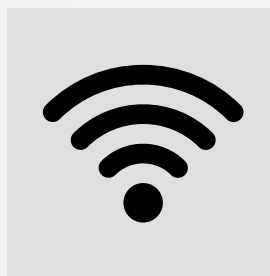

MONITORING
AND TRACKING

BRAND LOGOS



ENSIM SENSORS



ELORION SENSORS



CIHAZSEPETI



ENSIMSIGHT



ENBELLOW



ENABAR



ENVORTEX



ENFLOWS



WATERSENS



FUELSENS



MY ENSIM



ENSIM LIVE

CATALOG CONTENTS

LEVEL



ECAP	1
ECAS	2
ECAPm / ECAPr / ECAPe	3
ECASm / ECASe / ECAM	4
ELS	5
ELS-tx	6
ELB	7
ELG	8 - 9
EMT	10
ELH	11
ELF	12 - 13
ELM	14
ELP	15
ELC	16
ISS / ELC	17
WATERSENS / OILSENS	18
ELW	19 - 20
EGW	21
ELT	22
ELZ	23
E-TILT	24
ELA / ELAr	25
ELV / EYG	26
ELD	27

FLOW



EFS / EFD	28 - 31
ENABAR / ENVORTEX	32
EFO	33
EFM	34
EF (ELORION)	35-36

PRESSURE



EPS	37 - 39
ELX	40 - 41

TEMPERATURE



ETT	42
-----------	----

ANALYSIS & CONTROL



EPH (ELORION)	43
EBQ (ELORION)	44 - 46



ECAP CAPACITIVE TYPE LEVEL TRANSMITTERS



► Technical Specifications

Supply	: 24 VDC
Signal Output	: 4-20 mA two wires Std. 0-20 mA - 4-20 mA, 0-10 V three wire Opt.
Accuracy	: ± % 0,5 , ± % 0,8 , ± % 1
Linearity	: % 0,5
Capacity Range	: 1 pF...3n F 1,6 r ε
Connection Material	: 304 St.St. , Opt. 316 St.St.
Isolation Material	: PFA Std. Opt. PEEK, PTFE , Rubber, FKM
Housing Material	: PBT Std., Ops. Aluminium, St.St.
Working Pressure	: (-)1 bar...(+) 100 bar (Depending on the model)
Protection Class(EN60529)	: PBT-IP 66 , Aluminium , St.St. IP 65
Working Temperature	: (-) 40 °C / (+) 150 °C (Depending on the model) 200 °C with cooling apparatus (-) 196 °C For Cryogenic Tank, (-) 50 °C ...(+) 80 °C For NBR For FKM (-) 30 °C ...(+) 200 °C 400 °C with ceramic isolation
Ambient Temperature	: (-) 20 °C / (+) 60 °C
Display	: With LED-Power and Contact LED
Isolation	: Max. 500 V
Power Consumption	: Max. 50 mW
Electrical Connection	: Terminals
Protection Class (EN60529)	: IP 65, IP 66, IP 68

► ECAP

► DX-ECAP

Supply	: 24 VDC
Signal Output	: 4-20 mA two wires Std. 0-20 mA - 4-20 mA, 0-10 V three wire Opt.
Accuracy	: ± % 0,5 , ± % 0,8 , ± % 1
Linearity	: % 0,5
Capacity Range	: 1 pF...3n F 1,6 r ε
Connection Material	: 304 St.St. , Opt. 316 St.St.
Isolation Material	: PFA Std. Opt. PEEK, PTFE , Rubber, FKM
Housing Material	: Aluminum Injection - AISi12Fe (Std)
Working Pressure	: (-) 1bar...(+) 25 bar (Depending on the model)
Protection Class	: IP 66
Working Temperature	: (-) 40 °C / (+) 150 °C (Depending on the model) 200 °C with cooling apparatus (-) 196 °C For Cryogenic Tank, (-) 50 °C ...(+) 80 °C For NBR For FKM (-) 30 °C ...(+) 200 °C 400 °C with ceramic isolation
Ambient Temperature	: (-) 20 °C / (+) 60 °C
Display	: With LED-Power and Contact LED
Isolation	: Max. 500 V
Power Consumption	: Max. 50 mW
Electrical Connection	: Terminals
Protection Class	: IP 66, IP 68

ECAP level transmitter is a capacitive level sensor for level measurement of conductive liquid, low conductive liquid, granulated materials with solid particles, adhesive and acid/basic liquids. When a material comes between electrode rod and tank wall, a capacitance change occurs and when this change exceed adjustment threshold, contact output is delivered. Full-empty calibration can be performed easily and safely.

Different designs and different solution related to industrial levelmeasurement are offered especially for machinery manufacturers.

Application Areas :

Liquid tanks, food machines, cooling liquid tanks, shipping, glycol tanks, brine, waste water tanks. Oil tanks, CO2 liquid tanks, high temperature tanks, non-conductive liquids. Grain stores, cement, sand feed, flour, milk powder, organic and plastic granule. Sticky hot and high viscosity liquid, acid and chemical liquids.

Advantages :

There are no moving parts. High pressure and temperature resistant design.
Modular structure with easy assembly. Not affected by foam, liquid splashes.
Not affected by vibration, has robust mechanical structure.
Zero span adjustment is easy.Measurement along whole sensor.
Operability with reverse assembly.

For Conductive liquids ECAP 100 series
For Low conductive liquids ECAP 200 series
For Solids particulate materials ECAP 300 series
For Adhesive and acid/basic liquids ECAP 400 series

ECAS CAPACITIVE TYPE LEVEL SWITCHES



► Technical Specifications

Supply
Signal Output
Min. Di-Electric Constant
Connection Material
Isolation Material
Housing Material
Working Pressure
Working Temperature

Ambient Temperature
Display
Isolation
Power Consumption
Electrical Connection
Protection Class (EN60529)

► ECAS

: 24 VDC
: 1 NONC x 5 A / 250 VAC Relay
1,6 εr
304 St.St. , Opt. 316 St.St.
: PTFE, PFA Opt. Peek, Ceramic
: PBT (Std.) Opt. Aluminum Injection, St.St.
: (-)1 bar...(+) 100 bar (Depending on the model)
: (-) 40 °C / (+) 150 °C (Depending on the model) ,
200 °C with cooling apparatus
230 °C with Peek isolation,
400 °C with ceramic isolation
: (-)20 °C...(+) 60°C
: With LED-Power and Contact LED
: Max. 500 V
: Max. 1 W
: Terminals
: IP 65, IP 66, IP 68

► DX-ECAS

: 24 VDC
: 1 NONC x 5 A / 250 VAC Relay
1,6 εr
304 St.St. , Opt. 316 St.St.
: PTFE, PFA Opt. Peek, Ceramic
: Aluminum Injection , AISi2Fe (Std) Black
: (-) 1bar...(+) 25 bar (Depending on the model)
: (-) 40 °C / (+) 150 °C (Depending on the model) ,
200 °C with cooling apparatus
230 °C with Peek isolation,
400 °C with ceramic isolation
: (-)20 °C...(+) 60°C
: With LED-Power and Contact LED
: Max. 500 V
: Max. 1 W
: Terminals
: 66, IP 68

ECAS level switch is a capacitive level sensor for level measurement of conductive liquid, nonconductive liquid, granulated materials with solid particles, adhesive and acid/basic liquids. When a material comes between electrode rod and tank wall, a capacitance change occurs and when this change exceed adjustment threshold, contact output is delivered. Designed for difficult process conditions. Refrigerated models can be manufactured for high temperature and pressure conditions. Calibrations of triggering point and relay operation range can be performed by the user under workplace conditions. It can be connected horizontally or vertically.

Application Areas :

Liquid tanks, food machines, cooling liquid tanks, shipping, glycol tanks, brine, waste water tanks. Oil tanks, CO2 liquid tanks, high temperature tanks, non-conductive liquids. Grain stores, cement, sand feed, flour, milk powder, organic and plastic granule. Sticky hot and high viscosity liquid, acid and chemical liquids.

Advantages :

There are no moving parts. High pressure and temperature resistant design. Modular structure with easy assembly. Not affected by foam, liquid splashes. Not affected by vibration, has robust mechanical structure. Zero span adjustment is easy. Measurement along whole sensor. Operability with reverse assembly.

For Conductive liquids ECAS 100 series
For Low conductive liquids ECAS 200 series
For Solids particulate materials ECAS 300 series
For Adhesive and acid/basic liquids ECAS 400 series

ECAPm / ECAPr / ECAPe

OEM CAPACITIVE TYPE LEVEL SENSORS



► Technical Specifications

► ECAPm / ECAPr / ECAPe

Measurable Material	: Conductive liquids, refrigerants Non-conductive liquids Solids particulate materials Adhesive and acid/basic liquids
Supply	: 10...30 VDC Max.35 VDC 3-330 Ohm, 3-180 Ohm, 13-1300 Ohm...
Output	: (Check that it is compatible with the supply voltage of the relay operation.)
Capacity Range	: 1 pF...3 nF
Min. Di-Electric Constant	: 1,6 εr
Accuracy	: ± % 0.5 ... ± % 5 (Depending on the model)
Linearity	: % 0,5 Min 50 mm, Max. 2000 mm
Probe Length	: 304 Stainless Steel, Opt. 316 Stainless Steel
Connection Material	: Aluminium, PVDF, PTFE PFA Opt. PTFE, Delrin, Peek, Ceramic
Isolation Material	: Aluminium, Plastic
Isolation Material	: (-) 30 °C / (+) 150 °C (Depending on the model)
Working Temperature	: 200 °C with cooling apparatus 230 °C with Peek isolation
Working Pressure	: Max. 150 bar (Depending on the model)
Ambient Temperature	: (-)20 °C...(+) 60 °C, (-) 20 °C / (+) 80 °C
Power Consumption	: Max. 1 W, Max. 50 mW
Electrical Connection	: Terminals, Socket according to ISO 4400, Cable
Connection	: 1/2" BSP std. Thread Male (According to the order)
Max.Tensile Force	: Max. 10 Nm, 20 Nm, 40 Nm
Protection Class (EN60529)	: IP 65, IP 67

Advantages :

It can be able to calibrated by customer
There are no moving parts.
Not affected by vibration, has robust mechanical structure.
Measurement along whole sensor.
High pressure and temperature resistant design.
Easy assembly and sensitivity adjustment.
Not affected by foam, liquid splash and probe coating..

Application Areas :

Liquid tanks, food machines, cooling liquid tanks, shipping, glycol tanks, brine, waste water tanks.Oil tanks, CO2 liquid tanks, high temperature tanks, non-conductive liquids.
Grain stores, cement, sand feed, flour, milk powder, organic and plastic granule.
Sticky hot and high viscosity liquid, acid and chemical liquids.



Conductive Liquid



Low Conductive Liquid



Solids Particulate Material



Adhesive and Acid / Basic Liquid



ECASm / ECASe / ECAM

OEM CAPACITIVE TYPE LEVEL SENSORS



Technical Specifications

► ECASm / ECASe / ECAM

Measurable Material	: Conductive liquids, refrigerants Non-conductive liquids Solids particulate materials Adhesive and acid/basic liquids
Supply Output	: 10...30 VDC Max.35 VDC : 1 NO NC x 5 A / 250 VAC Relay (Delay 2 sec.) NPN or PNP Open Collector Transistor NO or NC (Please specify when ordering) (Check that it is compatible with the supply voltage of the relay operation.)
Capacity Range	: 1 pF...3 nF
Min. Di-Electric Constant	: 1,6 ϵ_r
Accuracy	: \pm % 0.5 ... \pm % 5 (Depending on the model)
Linearity	: % 0,5
Probe Length	: Min 50 mm, Max. 2000 mm
Connection Material	: 304 Stainless Steel, Opt. 316 Stainless Steel
Isolation Material	: Aluminium, PVDF, PTFE
Isolation Material	: PFA Opt. PTFE, Delrin, Peek, Ceramic
Working Temperature	: Aluminium, Plastic : (-) 30 °C / (+) 150 °C (Depending on the model) : 200 °C with cooling apparatus : 230 °C with Peek isolation
Working Pressure	: Max. 150 bar (Depending on the model)
Ambient Temperature	: (-)20 °C...(+) 60 °C, (-) 20 °C / (+) 80 °C
Power Consumption	: Max. 1 W, Max. 50 mW
Electrical Connection	: Terminals, Socket according to ISO 4400, Cable
Connection	: 1/2" BSP std. Thread Male (According to the order)
Max.Tensile Force	: Max. 10 Nm, 20 Nm, 40 Nm
Protection Class (EN60529)	: IP 65, IP 67

Advantages :

It can be able to calibrated by customer
There are no moving parts.
Not affected by vibration, has robust mechanical structure.
Measurement along whole sensor.
High pressure and temperature resistant design.
Easy assembly and sensitivity adjustment.
Not affected by foam, liquid splash and probe coating..

Application Areas :

Liquid tanks, food machines, cooling liquid tanks, shipping, glycol tanks, brine, waste water tanks.Oil tanks, CO2 liquid tanks, high temperature tanks, non-conductive liquids.
Grain stores, cement, sand feed, flour, milk powder, organic and plastic granule.
Sticky hot and high viscosity liquid, acid and chemical liquids.



Conductive Liquid



Low Conductive Liquid



Solids Particulate Material

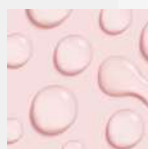

Adhesive and Acid / Basic Liquid

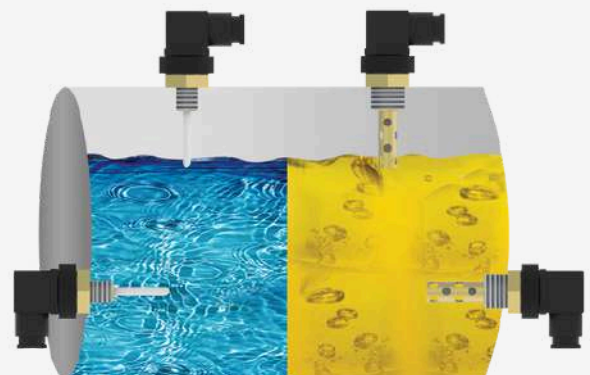

ELS FLOAT TYPE LEVEL SWITCHES



► Technical Specifications

Float Material	: 316 St.St. , PU
Wetted Parts Material	: 304 St.St. (Std.) Opt. 316 St.St.
Pipe Material	: 304 St.St. (Std.) Opt. 316 St.St.
Float Type	: S4A or S40A (Std.) Selectable from Table.
Working Temperature	: Max. 85 °C , 125 °C
Mechanical Connection	: 2 " BSP (Std.) Opt. Selectable
Electrical Connection	: Terminals , With Cable, With Socket
Number of Float	: 1 (Std.) More available
Stem Length	: Max. 2500 mm (Thread Including)
Number of Contact	: 2 x SPST - NO (Std.) Opt. It can be added
Contact Current	: 1,5 A (Std.)
Max. Contact Power	: 50 W / VA
Max. Supply Voltage	: 200 VDC / 250 VAC (Std.) Opt. Selectable
Protection Class (EN60529)	: IP 65, IP 66, IP 68

► ELS

► DX-ELS

: 316 St.St. , PU
: 304 St.St. (Std.) Opt. 316 St.St.
: 304 St.St. (Std.) Opt. 316 St.St.
: S4A or S40A (Std.) Selectable from Table.
: Max. 85 °C , 125 °C
: 2 " BSP (Std.) Opt. Selectable
: Terminals , With Cable, With Socket
: 1 (Std.) More available
: Max. 2500 mm (Thread Including)
: 2 x SPST - NO (Std.) Opt. It can be added
: 1,5 A (Std.)
: 50 W / VA
: 200 VDC / 250 VAC (Std.) Opt. Selectable
: IP 66, IP 68

ELS Level sensors are used for tank level control.
Different protection connection, material kinds are available.

Working Principle :

When magnetic field of magnet within the buoy moving along tube according to liquid level comes up to the reed sensor, it opens or closes the electric circuit. Such changes of reed sensors and alarm or level information can be assessed through a relay circuit or control device. It is preferred by the users because relay output is provided within the housing.

Advantages:

A variety of materials according to the flow
Different choices of ignition
Quick delivery
Different types of technics

Application Areas :

Tank level measurement and control, boiler kontrol, store room control, yacht water level control, sewage level control.
Hydraulic oil tank level measurement and control.



Conductive Liquid



Low Conductive Liquid

ELS-tx FLOAT TYPE LEVEL TRANSMITTERS



► Technical Specifications

Float Material	: 316 St.St. , PU
Wetted Parts Material	: 304 Stainless Steel (Std.) Opt. 316 Stainless Steel
Pipe Material	: 304 Stainless Steel (Std.) Opt. 316 Stainless Steel
Float Type	: S4A or S40A (Std.) Selectable from table
Working Temperature	: Max. 125 °C
Mechanical Connection	: 2 " BSP (Std.) Opt. Selectable
Electrical Connection	: Terminals , With Cable, With Socket
Number of Float	: 1 (Std.) More available
Stem Length	: Max. 6000 mm (Thread Including)
Supply	: 12...36 VDC
Output	: 4-20 mA (Std.) Two wires : Ops. 4-20 mA , 0-20 mA , 0-10 V , Ohm , Three wires
Frequency of Detection	: 15 mm / 10 mm / 5 mm
Protection Class (EN60529)	: IP 65, IP 66, IP 68

ELS-tx Level sensors are used for tank level control.

Working Principle :

When magnetic field of magnet within the buoy moving along tube according to liquid level comes up to the reed sensor, it opens or closes the electric circuit. Continuous type serial aligned resistance and reed relays are engaged and disengaged. Such changes of reed sensors and alarm or level information can be assessed through a relay circuit or control device. Precision of reed sensor increases according to lowness of its placement range. It is preferred by the users due to the advantages of providing analogue output within the housing. Furthermore, it is possible to follow and to control the process in the field through indicator.

Advantages:

- A variety of materials according to the flow
- Different choices of ignition
- Quick delivery
- Different types of technics

Application Areas :

Tank level measurement and control, boiler control, store room control , yacht water level control, sewage level control. Hydraulic oil tank level measurement and control.

► ELS-tx

► DX-ELS-tx

: 316 St.St.
: 304 Stainless Steel (Std.) Opt. 316 Stainless Steel
: 304 Stainless Steel (Std.) Opt. 316 Stainless Steel
: S4A or S40A (Std.) Selectable from table
: Max. 125 °C
: 2 " BSP (Std.) Opt. Selectable
: Terminals , With Cable, With Socket
: 1 (Std.) More available
: Max. 6000 mm (Thread Including)
: 12...36 VDC
: 4-20 mA (Std.) Two wires : Ops. 4-20 mA , 0-20 mA , 0-10 V , Ohm , Three wires
: 15 mm / 10 mm / 5 mm
: IP 66, IP 68

Application :



Conductive Liquid



Low Conductive Liquid

ELB LEVEL SWITCHES - SIDE MOUNTING



► Technical Specifications

Mounting Type	: Horizontal, Vertical
Flange Material	: 316 Stainless Steel
Float Material	: 316 Stainless Steel
Output	: 250 V AC 12 10 A , 220 V DC 12 0.6 A 0.2 bar ... 1 bar
Min. Density	: 0.70 g/cm ³ ; 0.75 g/cm ³ ; 0.80 g/cm ³
Housing Material	: Aluminum Injection , 304 Stainless Steel
Flange Dimension	: 92 mm x 92 mm , DN 65 , DN 80 , DN 100
Max. Pressure	: 16 bar , 25 bar, 100 bar
Max. Temperature	: 150 °C , 250 °C
Ambient Temperature	: (-) 20 °C / (+) 80 °C
Weight	: 1.8 kg...2.5 kg
Float Test Pressure	: 25 bar , 40 bar, 160 bar
Protection Class (EN60529)	: IP 65

► ELB

► DX-ELB

: Horizontal, Vertical
: 316 Stainless Steel
: 316 Stainless Steel
: 250 V AC 12 10 A , 220 V DC 12 0.6 A 0.2 bar ... 1 bar
: 0.70 g/cm ³ ; 0.75 g/cm ³ ; 0.80 g/cm ³
: Aluminum Injection , 304 Stainless Steel
: 92 mm x 92 mm , DN 65 , DN 80 , DN 100
: 16 bar , 25 bar, 100 bar
: 150 °C , 250 °C
: (-) 20 °C / (+) 80 °C
: 1.8 kg...2.5 kg
: 25 bar , 40 bar, 160 bar
: IP 66, IP 68

ELB level switches are used for measuring and checking level of tank. It is preferred in food, ship machine, boiler and storage tank applications with its advantages such as resistance to high temperature, long life contact structure, which is operable in each, vertical or horizontal connection.

Working Principle :

Microswitch changes direction with the movement, occurring after magnet in float arm, moving by changing liquid level, affects magnet inside body, magnetically obtained contact information is assessed by transferring into applications such as pump, solenoid valve etc.

Advantages:

- Max. 100 bar working pressure
- Max. 250 °C working temperature
- The apparatus diversity

Application Areas :

Food, ship, machine, boiler and storage tanks, hydraulic oil tanks, waste water tanks.

Accessories:



Bellows Apparatus



Counter Flange



External Tank



Test Apparatus



Conductive Liquid



Low Conductive Liquid

ELG MAGNETIC BY-PASS LEVEL INDICATORS



EN ISO3834-2



► Technical Specifications

Magnetic Display

Max. Working Pressure

Max. Working Temperature

Top / Bottom / Side

Flange

Body

Seal Material

Side Pipe Material

Connection Flange

Drain Screw Material

Bolt / Nut / Washer

Optional

► ELG

- : It is composed of sequential array of magnet sensitive flaps in the aluminium profile.
- : 16 bar, 25 bar, 40 bar, 100 bar
- : 180 °C, Ops. 350 °C, 60 °C
- : DN 32 / PN 16, 304 St.St. Opt. 316 Stainless Steel
- : Ø 140 / PN 40, 304 St.St. Opt. 316 Stainless Steel
- : Ø 195 / PN 100, 304 St.St. Opt. 316 Stainless Steel
- : Ø 60.3 x 1,5 / 2 / 3 / 3,5 mm, 304 St.St. Opt. 316 Stainless Steel
- : Ø 63 x 3 mm, PVC
- : Ø 63 x 2 mm, Titanium
- : Klingrid Opt. PTFE, Graphite
- : 304 St.St. Opt. 316 St.St. / PVC
- : DN 20 / PN 16, Carbon Steel
- : Opt. 304 / 3016 St.St. / PVC / Titanium
- : 1/2" BSP
- : 304 / 316 St.St.
- : M 12 x 45 mm / M 16 x 70 mm 304 Stainless Steel
- : Magnetic Contact
- : Analog Output, Scale, Drain Valve
- : Liquid Level Relay, Local Digital Display
- : Heating Jacket, Special Design

Advantages:

- For visual monitoring and control
- The analog signal can be output
- Different connection options
- Different material options
- Local digital display



ELG magnetic by-pass level indicators are assembled onto external or upper surfaces of tank, boiler and storage tanks. It enables to see level easily and with high accuracy. It is more economic than other measurement systems with mechanical method and it provides advantages for user with various assembly forms together with easy of assembly and maintenance.

Working Principle :

Liquid levels are the same in the main body of tank and level indicator in accordance with the principle of computational fluid. Float, which is available in the body and provides its rotation. Liquid level can be monitored easily from outside by means of two faces of flaps with different colors. Each indicator is delivered to customer after they are undergone from pressure, impermeability and final control tests after the production.

Application Areas :

Food, ship, machine, boiler and storage tanks, hydraulic oil tanks, waste water tanks.



Conductive Liquid



Low Conductive Liquid

ELG ACCESSORIES



► Technical Specifications

► MAGNETIC CONTACT - DX-ELG-K4

Contact Element	: Reed Sensor SPST-NO Hold Type	: Reed Sensor SPDT-NO/NC	: Reed Sensor SPDT-NO	: Reed Sensor SPDT-NO/NC (Std.)
*Contact Current	: 1,5 A	: 1 A	: 1 A	: 1 A
*Max. Contact Power	: 20 W / VA	: 20 W / VA	: 20 W / VA	: 20 W / VA
*Max.Switching Voltage	: 200 VDC / 250 VAC	: 150 VDC / 140 VAC	:	:
Case Material	: Aluminium, ALSi2Fe Black (RAL 9005)	: Aluminium, ALSi2Fe Black (RAL 9005)	: Aluminium, ALSi2Fe Black (RAL 9005)	: Aluminium, ALSi2Fe Black (RAL 9005)
Electrical Connection	: Terminal	: Terminal	: Terminal	: Terminal
Clamp Material	: 304 Stainless Steel	: 304 Stainless Steel	: 304 Stainless Steel	: 304 Stainless Steel
Operation Temperature	: (-) 20 °C...(+)145 °C	: (-) 20 °C...(+)145 °C	: (-) 20 °C...(+)145 °C	: (-) 20 °C...(+)145 °C
Working Temperature	: (-)40 °C...(+)60 °C	: (-)40 °C...(+)60 °C	: (-)40 °C...(+)60 °C	: (-)40 °C...(+)60 °C
Protection Class (EN60529)	: IP 66 / 68 It's attached to body clamp	: IP 66 / 68 It's attached to body clamp	: IP 66 / 68 It's attached to body clamp	: IP 66 / 68 It's attached to body clamp

► Technical Specifications

► TRANSMITTER - DX-ELG-T9

Housing	: Aluminium
Tube Material	: 304 Stainless Steel
Min. Measure.Distance	: 15 mm or 10 mm or 5 mm
Power Supply	: 10...36 VDC
Output	: 2 Wire 4-20 mA, 3-180, 10-180, 240-33 Ohm Opt. HART 3 Wire 4-20 mA, 0-20 mA, 20-4 mA, 20-0 mA, 0-10 V, 10-0 V, 1-5 V, 5-1 V, 0-5 V, 5-0 V
Clamp material	: 304 Stainless Steel
Electrical Connection	: Terminal
Operation Temperature	: (-) 20 °C...(+)145 °C
Protection Class (EN60529)	: IP 66 / 68
Working Temperature	: (-) 40 °C...(+) 40 °C It's attached to body clamp

DX-ELG series ex-proof magnetic contact and transmitter are used with magnetic level indicator. It can be used comfortably in environments that cause corrosion or high temperatures. Because, it does not have to contact with the liquid.

Working Principle :

Due to the reed relay and electronic circuit inside, DX-ELG series ex-proof magnetic contact and transmitter work with the magnetic field created by the float inside the magnetic level gauges. For this reason, they are mounted in the bodies of magnetic level gauges.

Advantages :

Economic
Short delivery time
Easy montage

EMT MAGNETOSTRICTIVE LEVEL TRANSMITTERS



► Technical Specifications

Material to Measure	: Liquid
Power Supply	: 24 VDC \pm 10%
Output	: 0...10V, 4...20mA, 0...20mA, 10...0V, 20...4mA, 20...0mA
Resolution	: 16 bit DAC Output \pm 0,02% Full Measurement (Min. 100 μ m)
Repeatability	: \pm 0,005% Full Scale
Measuring Length (L)	: 100...5000mm
Velocity	: < 10m/s
Sampling	: 2 kHz (Value can change by stem lenght.)
Max. Consumption	: 50mA -90mA (Value can change by stem lenght.)
Max. Output Noise	: < 5 mVpp
Max. Output Value	: 10.5 V
Update Time	: 0,5 ms...1000 m / 0,8 ms...2000 m
Permissible Applied Voltage	: Available (up to -30 VDC)
Over Voltage Protection	: Available (up to 40 VDC)
Connection (R)	: M18 x 1,5 mm Std.
Housing Material	: Aluminium
Connection Material	: 304 Stainless steel Std.
Pipe Material	: 304 Stainless steel Std.
Electrical connection	: Cable, M12-5Pin Socket
Protection Class (EN 60529)	: IP 66
Test	: EMC , Low Voltage
Mak. Tencile Force	: Max. 40 Nm
Working Temperature	: Max. 125 °C Opt. 150 °C
Working Pressure	: Max. 30 bar
Ambient Temperature	: (-)20°C / (+) 60°C

► EMT

Advantages :

High accuracy / precision (16 bit)
Long-working use
Short response time
Output signal options
Easy setup
IP66 Protection class

Application Areas :

Fuel Industry : Gasoline, diesel and liquid natural gas applications
Chemical Liquid Facilities : Pharmaceutical industries, biological engineering and similar chemical liquid mixing tanks
Water Management Facilities : Dam, Waste water sanitation facilities for real time monitoring
Food and Beverage Facilities : High sensitivity level monitoring for tanks contains liquid

EMT Magnetostriuctive Level Transmitter is a float type level sensor to be used measuring the level of liquids; designed especially for the difficult processes. Mounts vertically and can locate the very middle point of two opposite magnetic force fields by emitting signals. Therefore, no calibration or adjustment will be needed after the first set, even with the power cuts.

Furthermore, it's sensing element is in the body which prevents the wearing effects of the usage, sustains long term durability by avoiding the physical contact.



ELH REFLEX GLASS TYPE LEVEL INDICATORS



► Technical Specifications

Body Material	: Carbon Steel, Stainless Steel
Glass Material	: Borosilicate Glass
Cushion Gasket Material	: Klinger-sil14430, Graphite
Bolt Material	: Carbon Steel (6.8 x 8.8), Stainless Steel
Connection	: Flanged According to EN1092-1
Pressure Class	: PN 16, PN 40
Axis Dimension	: 300 mm...2500 mm
Max. Temperature	: 200 °C Opt. 300 °C
Test Pressure	: x 1,5

► ELH

Advantages:

- Economical
- Easy to read
- Can be used in high pressure steam

Spare Parts:

- Valves
- Glass
- O-Rings
- Glass seals

Reflex glasses are used for observing level in pressure tanks and high temperature liquids.

Working Principle :

Light refraction is different between liquids and gases. Liquids shows dark color due to absorption of light, however air and vapor shows bright color due to reflecting light. Reflex glasses do not get affected from thermal shocks and static temperature differences. It is not applicable(appropriate) for liquids that can harm the glass. (e.g. high temperature alkaline solutions and hydrofluoric acid)

Application Areas :

Steam tanks, loading-dumping tanks, chemical industry, petroleum product tanks, hygienic load tanks, fuel depots.



Conductive Liquid



Low Conductive Liquid

ELF ROTARY LEVEL SWITCHES

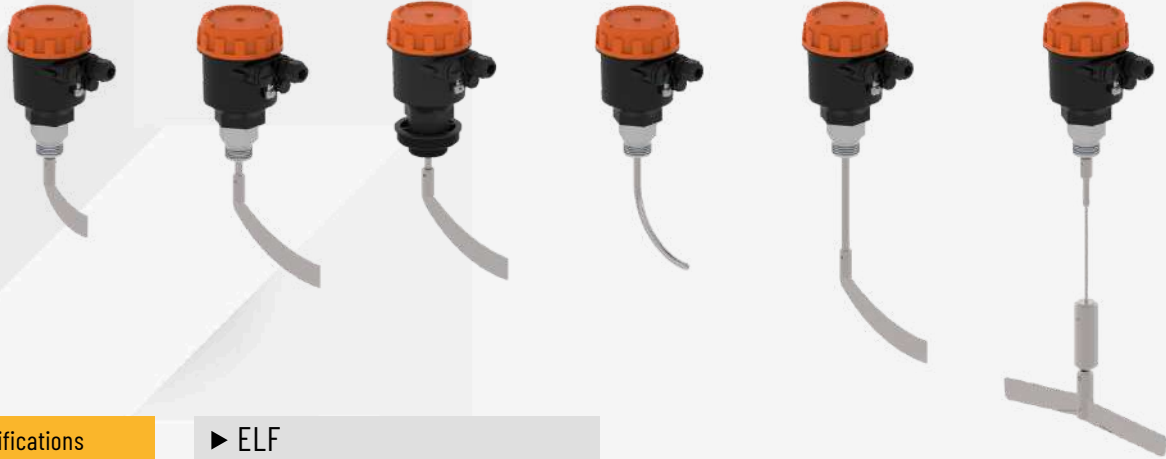

EAC CE

► Technical Specifications

Working Temperature

: (-) 20 °C....(+) 90 °C
 Opt. Max.150 °C With High Temperature Type (Plastic Housing)
 Max. 200 °C With High Temperature Type (Aluminium Housing)
 Max. 600 °C Very High Temperature Type

Ambient Humidity

: 0-98 % Rh (Non Condensate)

Ambient Temperature

: (-) 20 °C ... (+) 60 °C

Working Pressure

: (-) 0,6 bar... (+) 0,6 bar

Material Connection

: Aluminium (Std) Opt. 304 / 316 St. St., PTFE

Housing

: Antistatic Plastic (Std) Opt. Aluminium Enjection - AISi12Fe (Std)
 Body : Black Cover : Orange

Paddle And Rod

: 304 St. St. (Std) Opt. 316 St. St.

Extension Pipe

: 304 St. St. (Std) Opt. 316 St. St.

Grounding Apparatus

: 304 St. St.

Seal for Cover

: Elastomer Thermoplastic 120 °C (Std) Ops. FPM (Viton) 150 °C

Bearing

: Double ball bearing (With Dust-protected) (120 °C) Ops. 280 °C

Dust Protected Felting

: NBR (Std) Opt. FPM (Viton) 150 °C, PTFE 200 °C

Connection

: 1" BSP (Std) , Opt. 1 1/4" BSP , 1 1/2" BSP Male Thread

Power Consumption

: Max. 4 W

Revolutions Per Minute

: 5 Rpm (Std) (Clockwise - When Looking Paddle Side)
 Opt. 1,5-1,8 Rpm

Power Supply

: 24 VDC , ± 10 , 24 / 110 / 220 VAC 50/60 Hz ±% 10

Cable and stopper input

: PG 13.5 (Std) Opt. M 20 x 1,5 mm²

Relay switching capacity

: 2 A / 250 VAC 2 x NO/NC (SPDT) 5E4 Opt. 10 A / 250 VAC - 4A/30VDC

LED

: Power LED: Green , Alarm LED: Red

Max. Grain Structure

: 50 mm

Min. Density

: 0,04 g/cm³ (According to paddle type)

Torque Rating

: 4 Stages, adjustable

Load on probe

: Max. 500 N (Extention Pipe)

Protection Class (EN60529) IP 66

: IP 65, IP 66



Application Areas :

Plastic Industry ; PVC, PVDF, PP granular etc..

Food Industry ; Grain Dust, Ground Corn, Sugar-Granulated, Cacao, Malt-Graoung Dry, Sunflower Corn, Whead, Peanuts-Shelled, Clays- Kaoline, Talcum Powder, Ground-Paprika, Coffee-Roasted vb..

Build Industry ; Rocks-Limestone Crushed, Lime, Cement Powder, Rubber Ground, Lime Hydrate Dust, Calsium Dust, Iron Chips, Silica Sand, Moulding Sand, Styrofaam etc..

Wood Industry ; Wooden Fiberst, Saw Dust etc.. Other Chemistry Industry ; Coal Lump, Ash-Coal Dry etc..

DX-ELF ROTARY LEVEL SWITCHES

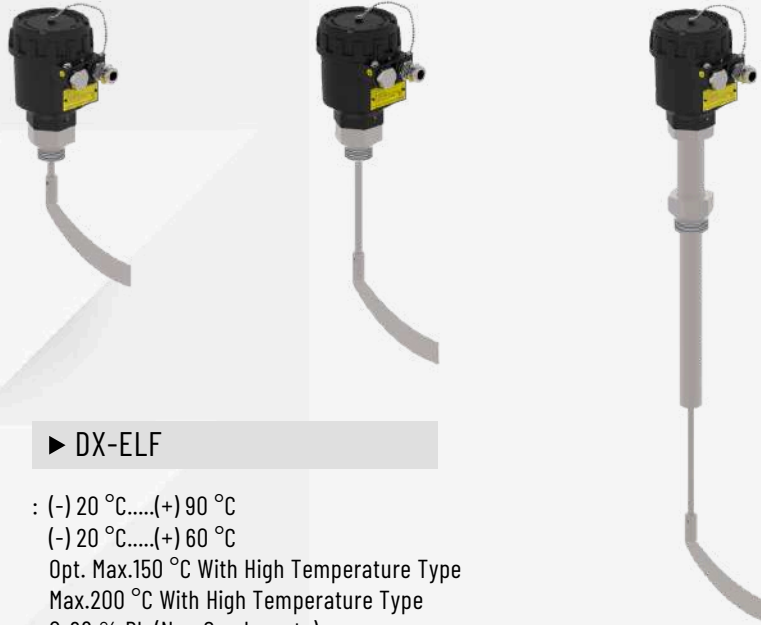

► Technical Specifications

► DX-ELF

Working Temperature	: (-) 20 °C.....(+) 90 °C (-) 20 °C.....(+) 60 °C Opt. Max.150 °C With High Temperature Type Max.200 °C With High Temperature Type
Ambient Humidity	: 0-98 % Rh (Non Condensate)
Ambient Temperature (Ta)	: (-) 20 °C ... (+) 60 °C
Working Pressure	: (-) 0,6 bar... (+) 0,6 bar
Material	Connection : Aluminium (Std) Opt. 304 / 316 St. St.
	Housing : Aluminium Enjection - AISi12Fe (Std) Black (RAL:9005)
	Paddle And Rode : 304 St. St. (Std) Opt. 316 St. St.
	Extension Pipe : 304 St. St. (Std) Opt. 316 St. St.
	Grounding Apparatus : 304 St. St.
	Seal for Cover : Elastomer Thermoplastic 120 °C (Std) Ops. FPM (Viton) 150 °C
	Bearing : Double ball bearing (With Dust-protected)(120 °C) Ops. 280 °C
	Dust Protected Felting : NBR (Std) Opt. FPM (Viton) 150 °C, PTFE 200 °C
Connection	: 1" BSP (Std) , Opt. 1 1/4" BSP , 1 1/2" BSP Male Thread
Power Consumption	: Max. 4 W (220 VAC) , Maks. 3 W (24 VDC)
Revolutions Per Minute	: 5 Rpm (Std) (Clockwise - When Looking Paddle Side) Opt. 1,5-1,8 Rpm
Power Supply	: Power Supply 24 VDC ± %10 , 24 / 48 / 110 / 220 VAC 50/60 Hz ± %10
Cable and stopper input	: M 20 x 1,5 mm ² (Std)
Relay switching capacity	: 10A/250 VAC - 4A/30VDC 2x NO/NC (SPDT) 5E4
LED	: Power LED: Green , Alarm LED: Red
Max. Grain Structure	: 50 mm
Min. Density	: 0,04 g/cm ³ (According to paddle type)
Torque Rating	: 4 Stages, adjustable
Load on probe	: Max. 500 N (Extention Pipe)
Protection Class (EN60529)	: IP 66, IP 68



Solids Particulate Material

Application Areas :

Plastic Industry ; PVC, PVDF, PP granular etc..

Food Industry ; Grain Dust, Ground Corn, Sugar-Granulated, Cacao, Malt-Graoung Dry, Sunflower Corn, Whead, Peanuts-Shelled, Clays- Kaoline, Talcum Powder, Ground-Paprika, Coffee-Roasted vb..

Build Industry ; Rocks-Limestone Crushed, Lime, Cement Powder, Rubber Ground, Lime Hydrate Dust, Calsium Dust, Iron Chips, Silica Sand, Moulding Sand, Styrofaam etc..

Wood Industry ; Wooden Fiberst, Saw Dust etc.. Other Chemistry Industry ; Coal Lump, Ash-Coal Dry etc..

ELM FLOAT TYPE LEVEL SWITCHES



► Technical Specifications

Float Material	: 304 St.St. , 316 Stainless Steel , PP
Wetted Parts Material	: 304 Stainless Steel , 316 Stainless Steel
Pipe Material	: 304 Stainless Steel , 316 Stainless Steel
Float Type	: S1Y , S3Y , S2A , S4A , S5A , S40A , P81
Working Temperature	: Max. 125 °C
Mechanical Connection	: 1/8" BSP , 3/8 " BSP , 1/2" BSP , 3/4" BSP M 10 x 1 mm ²
Max. Pressure	: 5 bar , 10 bar , 30 bar
Min. Density	: 0.70 g/cm ³ , 0.75 g/cm ³ , 0.85 g/cm ³
Electrical Connection	: Cable , Socket
Number of Float	: 1 Std.
Number of Contact	: 1 x SPST-NO , 1 x SPDT-NO / NC
Contact Current	: 0.7 A , 1 A , 1,5 A
Max. Contact Power	: 10 W / VA , 50 W / VA
Max. Supply Voltage	: 200 VDC / 140 VAC 180 VDC / 130 VAC 200 VDC / 250 VAC
Optional	: Liquid Level Relay SK-P2

► ELM

Advantages:

- Economic.
- Practical and easy installation.
- Fast delivery.
- Stainless steel material.



Conductive
Liquid



Low Conductive
Liquid

ELM level switches are used for checkin level of tank. It is preferred by machine manufacturers, especially in terms of its ease of use and economy. The ELM level switched can be mounted in litte places because of their mini design. The switches are made by.

Working Principle :

When magnetic field of magnet in the float is aligned with reed sensor in the tube , it opens or closes the electric circuit.

When float moves away , sensor reverts back (upon demand , drawn contact may be made). Level information can be assessed with a relay circuit.

Application Areas :

Machines, tanks, boilers, gas and liquid mediums, level measuring, temperature measuring...

LEVEL CONTROL DEVICE

Power Supply	: 220 VAC, 2.8 VA
Output	: 2 pcs. 5 A / 250 VAC Relay (Start/Stop)
Working Temperature	: (-) 20 °C...(+) 70 °C
Dimensions	: 72 x 72 mm
Input	: Contact information come from ELM
Isolation	: Input and output are isolated



SK-R
72mm x 72 mm

ELP FLOAT TYPE LEVEL SWITCHES



► Technical Specifications

Float Material	: PP , NBR , PVDF , Delrin
Wetted Parts Material	: PP , PVDF , Delrin
Pipe Material	: PP , PVDF , Delrin
Working Temperature	: (-) 20 °C / (+) 80 °C , (-)40 °C / (+) 80 °C , (-) 30 °C / (+) 120 °C
Max. Pressure	: Atm. , 2 bar , 4 bar , 10 bar
Min. Density	: 0.70 g/cm ³ , 0.75 g/cm ³ , 0.75 g/cm ³
Electrical Connection	: Cable , Socket
Number of Float	: 1 Std.
Number of Contact	: 1 x SPST-NO , 1 x SPDT-NO / NC
Contact Current	: 0,7 A , 1 A , 1,5 A
Max. Contact Power	: 10 W / VA , 50 W / VA
Max. Supply Voltage	: 180 VDC / 130 VAC , 200 VDC / 140 VAC , 500 VDC / 350 VAC

► ELP

Advantages:

Economic.
Practical and easy installation.
Fast delivery.
PP material.

ELP level switches are used for checking level of tank. It is preferred by machine manufacturers , especially in terms of its easy of use and economy.

The ELP level switched can be mounted in litte places because of their mini design. The switches are made by stainless steel material and so can be used in various liquids.

Working Principle :

When magnetic field of magnet in the float is aligned with reed sensor in the tube , it opens or closes the electric circuit.

When float moves away , sensor reverts back (upon demand , drawn contact may be made). Level information can be assessed with a relay circuit.

Application Areas :

Machines, tanks, boilers, gas and liquid mediums, level measuring, temperature measuring...

E-GSM Alarm Device - Double Entry

Battery or and supply
2 pcs. Lithium batteries,
12V adaptor (Included)
Excluding phone card.

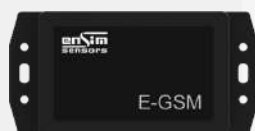

Conductive
Liquid



Low Conductive
Liquid

ELC LEVEL SWITCHES - Conductivity Type



► Technical Specifications

Electrode Material	: 304 Stainless Steel , Opt. 316 Stainless Steel
Isolation of Electrode	: Special Tubing , PTFE , PBT , PVDF, Delrin
Connection Material	: 304 St.St , 316 St.St , PTFE , PBT, Delrin
Housing	: 304 St.St, 316 St.St , PTFE , PBT, Delrin
Max. Working Temp.	: 60 °C , 80 °C , 100 °C ,120 °C , 200 °C , 225 °C
Max. Working Pressure	: 6 bar , 10 bar, 25 bar , 30 bar , 40 bar
Voltage Probe	: Max. 6 VAC
Mechanical Connection	: 1/4" BSP , 1/2" BSP / NPT , 1" BSP
Electrical Connection	: PG 7 , PG 13.5 , Terminals , Socket

► ELC

Working Principle :

When liquid level comes to the level of isolated electrode, current passage starts or stops between electrode and liquid. Strengthened this AC current may be assessed with a relay circuit.

ELC level switches are used for checking liquid level of tanks and boilers. As it does not have any movable part, it can be used in the critical ambient and in the liquids with solid particle, low density and high viscosity.

Advantages:

- Economical
- Easy to install
- No moving parts

Application Areas :

It is an economic and safe solution for air pressure tank applications, water level control of steam boilers and conductive tanks.



Conductive Liquid



Low Conductive Liquid

ISS LEVEL SWITCHES - Conductivity Type

ELC LEVEL SWITCHES - Conductivity Type



► Technical Specifications

► ISS

► ELC

Mounting Position	: Vertical (into boiler or with by-pass tube)
Process Connections	: 1" BSP , 2" BSP
Working Pressure / Temperature	: Max. 32 bar , Max. 238 °C , 6 bar, 10 bar, 25 bar..
Housing	: PC, Aluminum Casting (Electrostatic Painted)
Connection Material	: 316 Stainless Steel
Electrode Isolation	: Special Tubing, PTFE, PBT, PVDF, Delrin
Pipe Part	: PTFE
Electrode Material	: 304 Stainless Steel, 316 Stainless Steel
Pipe Material	: 304 Stainless Steel, 316 Stainless Steel
Electrode Length	: 500 mm , 1000 mm , 1500 mm
Electrode Diameter	: 4 mm
Cable	: 5x0.75 mm ² With Silicon Insulated
Cable Entry	: 3 pcs. PG 11 Chromed Brass, PG7, PG13,5, Socket
Supply	: 220-240 VAC (Std.) or 24 VDC (Opt.) , 2 VA
Electrode Voltage	: Max. 6 VAC
Sensitivity	: 1 uS/cm min. or 30 uS/cm min. selectable
Output	: Contact
Contact Current	: 4 x 8 A / 250 VAC
Relay Delay	: 3 sec.
Ambient Temperature	: 70 °C
Protection Class (EN60529)	: IP 65

ISS Level Sensor is designed for controlling of conductive measurement principle. It has four different measurement probe and an electronic unit and so without any other control unit it allows to control by itself. The sensor has two different conductive level measurement and four different control function, which are selectable by user. It can be used in min.1 μ S/cm and over conductive liquids.

Advantages:

- Compact structure.
- Multi-function can be controlled.
- Wetted parts is 316 stainless steel.
- Low conductivity liquids can be worked.

Application Areas :

It is an economic and safe solution for air pressure tank applications, water level control of steam boilers and conductive tanks.
Degasifier , Steam boilers, Condansate tanks , Conductive liquid tanks...



Conductive Liquid



Low Conductive Liquid

WATERSENS / OILSENS LIQUID WARNING DEDECTOR



► Technical Specifications

Display	: 3 each Alarm LED
Siren	: 1 each Siren + On / Off Button
Sensor	: Bipolar Cable, 1 m. Std. Three sensors can connect devices
Supply	: 9 V Square Alkaline Battery or 24 VDC
Output	: 2 A / 125 VAC NO / NC
Battery life	: 2 years for storage
Housing	: ABS Plastic, Black Colour (Opt.Grey) (Inbox; 1 each watersens and probe 1 each Battery, 1 each Double-sided tape 2 each Wall mounting bracket)
Weight (With package)	: 190 g.
Dimenson	: 70 mm x 100 mm x 22 mm

► WATERSENS

► Tech. Specifications

Supply	: 18-29 VDC
Cable	: 3 x 0.22 mm ² or 5 x 0.22 mm ² , 2 m.Std.
Output	: PNP-NO / NC Max. 100 mA NPN-NO / NC Max. 100 mA RELAY-NO / NC Max. 300 mA In order to be indicated.
Connection	: 3/4" NPT Double Sided
Body Material	: PP Opt. Stainless Steel
Working Temperature	: Max. 85 °C
Working Pressure	: Max. 20 bar
Mounting	: Connected Vertically or Horizontally
Protection Class (EN60529)	: IP 68
Min. Conductivity	: 100 microSiemens / cm

► OILSENS

Supply	: 18-29 VDC
Cable	: 3 x 0.22 mm ² or 5 x 0.22 mm ² , 2 m.Std.
Output	: PNP-NO / NC Max. 100 mA NPN-NO / NC Max. 100 mA RELAY-NO / NC Max. 300 mA In order to be indicated.
Connection	: 3/4" NPT Double Sided
Body Material	: PP Opt. Stainless Steel
Working Temperature	: Max. 85 °C
Working Pressure	: Max. 20 bar
Mounting	: Connected Vertically or Horizontally
Protection Class (EN60529)	: IP 68
Min. Conductivity	: 100 microSiemens / cm

Watersens is used in order to detect the flood in advance and to take precaution at homes and offices. It can be powered by 9V. battery.

It can be ensured to stop any water leakage by commanding relay output to a solenoid valve. It can avail people around it to take precautions by attracting their attention through siren.

WATERSENS P / N / R is used in order to determine the water level and to take precaution in the facilities. It ensures the people in the ambient to take precaution by attracting their attention through siren in order to determine high water or low water level.

Its electronic card is in the upper box and it is insulated with resin. It is not affected by water.

Electrode material has been selected as stainless steel and its electronic design has been performed specially in order that there is no electrolysis in the lead terminals.

It is appropriate to submerge a weight onto the tooth on the submersion probe.

Application Areas :

Operation rooms, computer rooms, warehouses, generator rooms, compressor rooms, air conditioner rooms, baths, kitchens and all locations having possibility of flood, fire alarm systems, wells, for high water detection, ship tanks, water level control, water leakage.

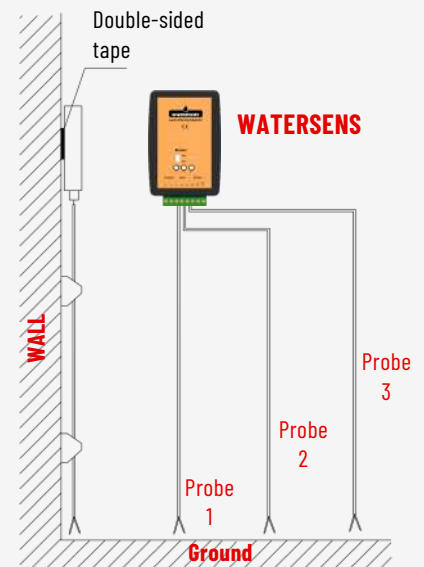

Conductive Liquid



Low Conductive Liquid

ELW RADAR TYPE LEVEL TRANSMITTERS



► Technical Specifications

► ELW 101

► ELW 102

Material to Measure	: Liquid, Solid Particulate Materials, Aggressive Liquids	: Liquid, Solid Particulate Materials, Aggressive Liquids
Range	: 0...20 m	: 0...10 m / 20 m / 30 m / 70 m
Accuracy	: $\leq \pm 2$ mm	: $\leq \pm 3$ mm $\leq \pm 5$ mm
Settings Menu Language	: English	: English
Sensitivity	: ± 3 mm	: ± 3 mm
Repeatability	: $\pm 1,5$ mm	: $\pm 1,5$ mm
Resolution	: 1 mm	: 1 mm
Frequency	: 26 GHz / 80 GHz	: 26 GHz / 80 GHz
Dielectric Constant (e)	: Min. 1,4 (Selectable five different way.)	: Min. 1,4 (Selectable five different way.)
Response Time	: < 2 sec	: < 2 sec
Sampling Frequency	: 54 GHz	: 54 GHz
Indicator and Adjustment	: LCD Display	: LCD Display
Cable Input	: M20x1,5mm	: M20x1,5mm
Electric Connection	: Terminal	: Terminal
Process Connection	: G 1½" (Std.), G 3"	: G 1½" (Std.), G 3"
Antenna Type	: Rod Type	: Horn Type
Antenna Material	: PTFE, 316L Stainless Steel	: PTFE, 316L Stainless Steel
Housing Material	: Aluminum Injection AlSi2Fe Black (RAL9005) (Std)	: Aluminum Injection AlSi2Fe Black (RAL9005) (Std)
Connection Material	: 304 /316 Stainless Steel	: 304 /316 Stainless Steel
Working Temperature	: (-) 40 °C...85 °C	: (-) 40 °C... (+) 150 °C Opt. 250 °C
Ambient Temperature	: (-) 20 °C...60 °C	: (-) 20 °C...60 °C
Relative Humidity	: $< \% 95$: $< \% 95$
Working Pressure	: (-) 0,8 bar... (+) 3 bar	: (-) 1 bar... (+) 40 bar
Beam Angle	: 20 °	: 18 ° / 12 ° / 8 ° / 6 °
Supply Voltage	: 15...36 VDC 2 Wires Version	: 15...36 VDC 2 Wires Version
Power Absorption	: $< 0,5$ W	: $< 0,5$ W
Output Signal	: 4-20 mA 2 Wires + HART (Resolution 1,6 mikro A)	: 4-20 mA 2 Wires + HART (Resolution 1,6 mikro A)
Error Signal	: 20.5 mA; 22 mA ; 3,9 mA (Adjustable)	: 20.5 mA; 22 mA ; 3,9 mA (Adjustable)
Integration Time	: 0... 20 s., Programmable	: 0... 20 s., Programmable
Weight	: ~ 2 ... 4 kg	: ~ 2 ... 4 kg
Protection Class (EN60529)	: IP 66	: IP 66

Advantages :

Compact structure , Easy to setup , Durable mechanical construction , High temperature models available.

Application Areas :

Almost for all liquids and solid particules. Especially with abrasive/aggressive liquid level measurement applications.

Such as ; Chemical, and pharmaceutical industries, food and plastic industries, power plants, oil and cement factories. Water, acid and oil tanks, Cement and klin silos. Grain and livestock feed silos. Fire water tanks, rivers, waste material and waste water applications.

ELW 3D PRO



► Technical Specifications

► ELW 3D PRO

Frequency	: 120 GHz - 140 GHz
Application	: Bulk solids, grains , powders
Measuring range	: 20...120 meter
Measurement accuracy	: level accuracy ± 2 mm;
Beam angle	: 3D modeling 1%...5%
Horizontal rotation	: 1.5°
Angle range	: 0...360 °
Horizontal step angle	: 1 ° (adjustable)
Pitch measurement angle	: single direction -90 °...90 ° (settable)
Pitch step angle	: 1 ° (adjustable)
Power supply	: 24VDC
Consumption	: 8W
Process temperature	: -40 ° C~75 ° C
Process pressure	: 0...1bar
Process connection	: \geq flange DN200
Communication	: MODBUS RS485;Ethernet; FDDI;4G;5G
Signal output	: 4...20mA, RS485, MODBUS TCP, OPC,Web API
Housing material	: 6061 Aluminium alloy or Nylon
Protection	: IP67
Dimension	: 308.50×185mm
Weight	: 5Kg



ELW 3D PRO radar level scanner integrated with technology of image processing, big data analysis, AI artificial intelligence, machine learning, 3D points cloud conversion and 3D modeling, cloud storage and computing. ELW 3D PRO radar level scanner accurately detect the 3D information of solid materials and buildup on the wall of the silos. Integrated with technology of image processing, big data analysis, AI artificial intelligence, machine learning, 3D points cloud conversion, 3D modeling and cloud storage it solves the key problems of material storage and level measurement, making material management intelligent and visible. ELW 3D PRO radar level scanner brings customers Faster, Safer and Smarter process Control.



Conductive
Liquid



Low Conductive
Liquid



Solids Particulate
Material



Adhesive and
Acid / Basic Liquid

EGW GUIDED RADAR (TDR) LEVEL TRANSMITTERS



► Technical Specifications

Material to Measure Range	: Liquid, Solid Particulate Materials, Aggressive Liquids : 32 m. Wire Rope Probe : 6 m. Rod Probe : 4 m. Coaxial Probe
Settings Menu Language	: English
Sensitivity	: ± 3 mm
Repeatability	: ± 1,5 mm
Resolution	: 1 mm
Working Pressure	: (-)1...(+)40bar , Opt. Max. 100bar
Working Temperature	: (-)40...(+)200°C , Opt. Max. 450°C
Ambient Temperature	: (-)20...(+)60°C
Frequency	: 106 MHz - 1,8 GHz
Dielectric Constant (ε)	: Min. 1,4 (Selectable five different way.)
Response Time	: <2 sec
Sampling Frequency	: 16 Hz
Power Absorption	: <0,5 W
Supply Voltage	: 15...36 VDC 2 Wires Version (Resolution 1.6 micron A)
Output Signal	: 4-20mA 2 Wires + HART
Error Signal	: 20,5 mA , 22mA , 3,9 mA (Adjustable)
Maks. Load Resistance	: 500 W
Damping Time	: 0...90 sn.
Housing Material	: Aluminum Injection AISi2Fe Black (RAL9005)
Connection and Insulation Material	: 304 Stainless Steel (Std.) , Opt. 316 Stainless Steel : PTFE (Std.) , Opt. PEEK , Ceramic
Indicator and Adjustment	: LCD Display
Cable Entry	: M20 x 1,5 mm
Electrical connection	: Terminal
Protection Class	: IP66 (EN60529)
Weight	: EGW 205, (For L = 1000mm) ... kg

Advantages:

- Compact structure
- Easy to setup
- Durable mechanical construction
- High temperature models available

Areas of Application :

- Volatile liquids, foamy liquids,
- viscous liquids, boiling and foaming liquids, crude oil tanks.



Conductive Liquid



Low Conductive Liquid

Working Principle:

High frequency microwave pulses are guided along a steel rope or rod. When they reach the product surface, the reflected waves are detected by the electronics. The flight time of the signal (between sending and detecting time) is directly proportional to the level.

The Guided Radar Level Transmitter is used for continuous level measurement of liquids and solids. There are models that can be used in difficult working conditions. It provides reliable and accurate measurement in case of dust and noise, without being affected by accumulation and condensation. Measurement is not affected by specific gravity of the medium, condensation, fluctuation and variation of the dielectric constant (in the setting range). It has easy and simple use. It can be configured with 4 buttons on LCD display.

ELT - DX-ELT VIBRATING ROD TYPE LEVEL SWITCHES



► Technical Specifications

► ELT - DX-ELT

Fluid	: Liquid, Solid, Powder
Wet Parts	: 316 Stainless Steel
Fork Material	: 316 Stainless Steel
Housing Material	: Aluminum, Stainless Steel (For ELT103)
Max. Solid Particle Size	: <10 mm
Max. Liquid Viscosity	: <1000 mm ² / sec
Measurement Density	: For Solid > 0,1 g / cm ³ For Liquid > 0.7 g / cm ³
Vibration Frequency	: 280 KHz (For ELT102,104, 202, 204) 300 ± 50KHz (For ELT101, 201)
Delay Time	: 0.5 sec (Vibration Stop) : 1-2 sec (Vibration Start) It can be adjusted between 1-60 seconds
Exit	For (ELT101, ELT103m, 201,1 05, 205) : 2 x 5A NO / NC Relay 30 VDC / 220 VAC For (ELT103) : 1 x 5A NO / NC Relay 30 VDC / 220 VAC For (ELT103m) : 1 x 5A NO Relay 30 VDC / 220 VAC For (ELT102,104, 202, 204) : 2 x 8A NO / NC Relay 24 VDC / 220 VAC
Supply	: 15-80 VDC, 15-260 VAC
Power consumption	: 2.5 W, 1 W (For ELT103)
Connection	: 1" BSP (Std.) Male Thread Opt. Flanged
Working Pressure	: Max. 20 bar (For ELT101, 201) Max. 40 bar (For ELT102,104, 202, 204) Max. 30 bar (For ELT103)
Working Temperature	: (-) 20 °C ... (+) 150 °C (Std.) Opt. 200 °C
Ambient Temperature	: (-) 20 °C ... (+) 80 °C
Ambient Humidity	: % 95 RH
Protection Class (EN60529)	: IP 66, IP 67 (For ELT103)

Advantages:

Suitable for side as well as top mounting
Minimum and maximum fail safe field selectable.
Process pressure max. 40 bar
Process temperature max 200 °C
Low power consumption.
No Calibration Required
Settable switching delay as a standard feature
Durable Construction
Immune to External Vibrations

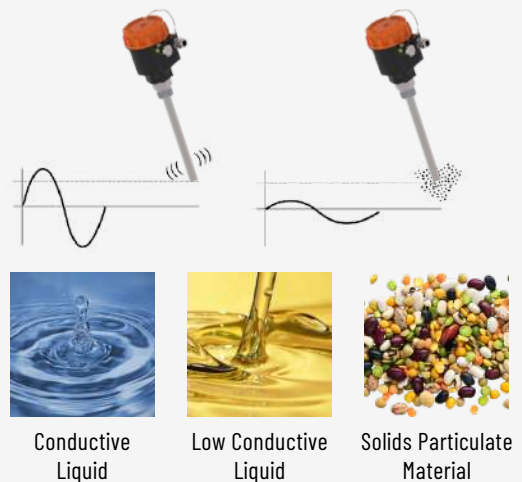

ELT series single vibrating material level switch is one of the tuning fork material level switches. It is not afraid of hanging materials, not afraid of impact, without clamping problems, and has higher sensitivity. Its cylindrical single measuring rod structure determines its wider adaptability to industrial field. Single rod vibrating level switch uses the "resonance" principle of tuning fork to generate vibration under the driving of piezoelectric elements. Only when all around the probe rod are surrounded by materials, the vibration amplitude will be sharply reduced, resulting in switch action.

Areas of Application :

It can be used in process that containers , silos , free flowing dusts, granules and various types of small particulate solids such as cereals, beans, edible oil process, sugar, animal feed, rice plants, detergents, dye powder, chalk, gypsum, fly-ash, cement, sand, plastic granules, spices, milk powder etc.

ELZ LEVEL SWITCH WITH DIAPHRAGM



EAC CE

► Technical Specifications

Installation	: Vertical
Material	: Fiber reinforced plastic. Opt. Aluminum Casting
Diaphragm	: Neoprene, Viton, Stainless Steel
Working Temperature	: (-) 20...(+) 80 ° C ELZ with NBR diaphragm 11 : (-) 20...(+) 150 ° C with Viton diaphragm ELZ 21 : (-) 20...(+) 200 ° C Rust. Diaphragm with ELZ 31
Protection Class	: IP 40 IP 53 (If the mounting position of the compensating filter is downwards) IP 65 (For ELZ31)
Max. Working Pressure	: 3 bar, NBR, for Viton Diaphragm 1 bar Stainless Diaphragm for
Weight With box	: 525 g. Plastic Body 990 g. Aluminum Body
Accuracy	: 200 g. 600 g. Adjustable
Electrical Connection	: PG 13,5 Plastic, PG 11 Metal (ELZ31)
Contact Output	: 1 x SPDT 15 A / 250 VAC

► ELZ



Level control with membrane is the most economical method in measurement of level of bulk material in the storage. It can be used in open and non-pressure tanks. ELZ can check full, empty and loaded situations of powdered, dusty, corny, granular, grained bulk materials in the grain elevator. It is appropriate for using in the particles in 0,3 and 2,5 t/m³ and up to max. 30 mm. Membrane should contact with checked material certainly.

Advantages :

Economical.
Easy installation and commissioning.
Fast delivery.

Areas of Application :

Sugar, Hazelnut, Clay, Sunflower Seed, Coffee, Various Granules, Wheat, Bauxite, Ceramic, Legumes, Cereal, Fish Feed, Sand, Pebble, Isolation Materials, Corn, Rice ...



Solids Particulate Material

E-TILT TILT SENSORS



CE

► Technical Specifications

► E-TILT

Tilt Angle (Vertically left or right)	Max. Contact Current / Voltage
15 ° ± 3 ° (Std.)	1,5 A / 120 VAC NC 0.6 A / 240 VAC
25 ° ± 10 °	Opt. 1,5 A / 120 VAC 0.6 A / 240 VAC
35 ° ± 10 °	Opt. 12,5 A / 120 VAC 7A / 240 VAC
45 ° ± 10 °	Opt. 1 A / 120 VAC 0.4 A / 240 VAC
Max. Switch capacity	: 100 - 200 VA
Pipe Material	: 304 Stainless Steel Opt. 316 Stainless Steel, PVC
Working Temperature	: (-)40 °C / (+)100 °C
Cable Length	: 2 m. (Std) Can be added on request.
Cable Material	: PVC (Max. 60 °C) Opt. Silicon, Rubber
Protection Class (EN60529)	: IP 67



E-Tilt sensor is used vertically. It can be operated by battery and also it can be operated by providing the feeding. It can be ensured to stop the water leakage by commanding the relay outlet to a solenoid valve. Furthermore, it can benefit to take measure by attracting attention of the people in the ambient by sounding the siren. Its electronic design is specially designed in order that there is no electrolysis in the lead terminal by selecting stainless steel electrode material..

Advantages :

Easy installation, Economical, Resistant to corrosion.

Areas of Application :

Conveyor lines, silos, ship loading telescopic arms..



Solids Particulate
Material



ELA FLOAT LEVEL SWITCHES



EAC CE

► Technical Specifications	► ELA
Fluid	: Liquid
Appropriate Liquid Density	: Min. 0,85 g/cm ³ , 0,60 g/cm ³1.4 g/cm ³ 0,80 g/cm ³1.2 g/cm ³
Differential Angle	: 10 ° , 25 ° , 40 ° , 65 ° , 90 °
Working Temperature	: Max. 60 °C , 80 °C , 120 °C
Working Pressure	: Max. 2 bar , 5 bar , 10 bar
Material of float	: PU , 304 Stainless Steel , 316 St.St. , PP
Float Dimensions	: Ø 23 , Ø 26 , Ø 65 , Ø 80 , Ø 86 , Ø 115 mm
Material of cable	: 3 x 0,3 mm ² Silicon , 3 x 1 mm ² Silicon , 3 x 0,75 mm ² PVC
Contact Capacity	: Max.0,1 A / 60 VAC , Max.10 A / 120 VAC Max.1,5 A / 240 VAC - 2 A / 120 VAC 5 A / 250 VAC , 6 A / 250 VAC
Contact	: 1 x NO / NC , 1 x NO , 1 x NC
Protection Class (EN60529)	: IP 68
Process Type	: Filling / Emptying , Minimum , Maximum

Cabled level switches are used in order to ensure tank, depot, waste water plant level control in the industrial facilities and dwellings. It operates without any problem in the particulate ambient with its mechanical design and there is not any jam. Neoprene rubber cable is used for resistance against different liquids and in order that it does not crack in the hot-cold ambient.

Advantages:

Easy to install
Reliable
Economical

For example, it can be used on this fluids :

Water, waste water, diesel, fuel oil, glycerine, gas, nitric acid 10%, asetic acid 10%, formaldehyde 40%, lactic acid 10%, hydrochloric 10%, sophuric acid 30% etc...

Application Areas :

Fish ponds, swimming pools, groundwater, waste water pools, treatment pools, plunger pump applications, hydrophors, residential water tanks, etc..

ELAr DIRTY WATER FLOAT



► Technical Specifications	► ELAr
Working Pressure	: Max. 2 bar
Working Temperature	: (-)40 °C...(+) 70 °C
Contact Voltage	: 60 VAC
Contact Current	: Max. 0,1 A
Contact Capacity	: Max. 0,3 A
Contact Form	: 1 x NO / NC
Mechanical Connection	: 3/4" BSP Thread Male (Std)
Nut and Connection Material	: 304 Stainless Steel (Std) Opt. 316 Stainless Steel, Delrin
Float Material	: PU
Cable Material	: Silicon Cable (Std.)
Weight	: 290 g. (With Cable 1 m.)
Min. Density	: 0,70 g/cm ³
Cable Length	: 1 m. (Std) Opt. M12 Socket
Protection Class (EN60529)	: IP 65

ELR dirty water switch uses for the control of extreme dirty fluids.

It can be mounted to tank from within or outside without connection way requirement. It is perfect endurance with stainless steel record and nut.

PU material float is connected to body with silicon cable. It gives alarm information with NO or NC contact when nonmercury contact in float pass the horizontal slope angle. It is suitable for use on rail.

Advantages:

Not include magnetic parts.
Stainless Steel Design
Without mercury contact
Independent in terms of connection

Application Areas :

Train carriage and dirty water store of boat, dirty water tanks, tank include particulate dirty fluid...

ELV FLOAT VALVE



► Technical Specifications

Body Material	: 304 St. St. , ABS Opt. 316 St. St.
Piston Bracket Material	: 304 St. St. , ABS Opt. 316 St. St.
Piston Material	: 304 St. St. , ABS Opt. 316 St. St.
Bolt + Nut + Stamp + Pin Material	: 304 St. St. , ABS Opt. 316 St. St.
Seal Material	: Viton, NBR
Max.Working Temperature	: 200 °C, 60 °C
Max.Working Pressure	: 2 bar...10 bar

It is used checking liquid level in the tanks. Length of float can be adjusted with the arm, which is designed horizontally and vertically with the arm, with closed design. Valve is closed by increasing liquid level by using temperature resistance isolation material or on the contrary, valve is opened and starts to discharge with increase in the liquid level. When level decreases, valve is closed. Special connection and models can be made. Seal material can be selected in compliance with special liquids (oil, petrol, food fluids).

Advantages :

Special model can be produced upon demand.
Models with shorter valve arm can be produced.
Seal, which is resistant to oil, petrol or materials in the food sector.
Stainless steel

Areas of Application :

Tank, fire-fighting water tanks, for controlling the tanks which are in without electricity environment, condensate, tanks, food storage tanks, etc.



Conductive Liquid

EYG TANK LEVEL GAUGE



► Technical Specifications

Accuracy	: ± % 5
Operating Temperature	: (-) 40 °C / (+) 85 °C
Material of Connection	: PP
Connection	: 1 1/2" BSP Male (Std)
Scale	: PVC
Stem Length	: Max. 750 mm
Material of Float	: Polyurethane
Material of Display Cover	: Transparent Polycarbonate Crystal 304 Stainless Steel
Material of Guide Road	: 304 Stainless Steel
Material of Shaft	: NBR
Material of Ring	:

EYG Tank level indicator is manufactured for displaying the level in the tank.
Easy and quick levels can be seen by users.
Installation can be made in a simple way.
EYG usually used in hydraulic and fuel level measurement.

Advantages:

Economical
Practical and easy mounting
Quick delivery time
Complete Stainless Steel.

Application Areas :

Machinery, hydraulic oil tanks, small ware house etc.



Conductive Liquid



Low Conductive Liquid

ELD LEVEL INDICATORS

CE



► Technical Specifications

Body Material	: Transparent Plastic, Steel, Aluminium, Stainless Steel
Seal Material	: NBR , PTFE , Viton
Max. Working Pressure	: 2 bar , 15 bar
Max. Working Temperature	: 60 °C , 80 °C , 150 °C
Display Material	: Plastic , Glass

► ELD

► Technical Specifications

Transparent Monitoring Pipe	: Acrylic Pipe or Borosilicate Glass
O-Ring	: NBR, Opt. Viton
Working Temperature	: Std. 60 °C (Acrylic) Ops. 180 °C (Glass)
Max. Working Pressure	: 2 bar , 6 bar
Connection Material and Shafts	: 304 Stainless Steel , 316 St.St. , U-PVC
Float Material (Opt.)	: 304 Stainless Steel

► ELD

Advantages:

- Liquid easily can be discharged by changing valves position
- Easy installation
- Indicator can be chosen via material types
- As optional, a contact can be mounted.
- Resist to high temperature.
- Resist to high pressure.
- Economical

It is an economic level monitoring indicator, which is designed for monitoring flow in the pipe lines for machine manufacturers, food factories. It can be installed horizontally or vertically.

Areas of Application :

Hydraulic tanks, pressure vessels, cooling tanks, hydraulic lines and oil vessels.

CAPACITIVE CONTACT

The magnetic contact works according to capacitive working principle and used to receive liquid flow information without any metal parts. Accuracy can be arranged via potentiometer setting and with a led, it gives visual information to users. It can be used as a flow switch. Beside it can be used to take min. and max. contact information.



Conductive Liquid



Low Conductive Liquid

► Technical Specifications

Surface of tank	: Max.10 mm. (ELD-A)
Suitable Pipe	: Ø 8 - 12 mm (Thicknes max. 1 mm.) (ELD-B)
Diameter	: Ø 12 - 26 mm (Thicknes max. 1.5 mm.) (ELD-C)
Material of Body	: ABS Plastic (Heat resistant) 32 x 19 x 10 mm
Protection Class	: IP 66
Weight	: 70 g.
Leght of Cable	: 2 m.
Working Temp.	: 60 °C
Supply	: 12...24 VDC
Load	: 300 mA max.
Color	: Black
Response time	: LED
Output	: 0,5 sec.
	: NPN - NO

CAPACITIVE CONTACT

EFS FLOW SWITCHES



► Technical Specifications	► EFS ..s / DX-EFS ..s (Stainless Type)	► EFS ..p (Plastic Type)
Material	Body+Thread+Nut : AISI 304 St.St. (Opt. AISI 316 St.St.) Relay Case : AISI 304 St.St. (Opt. AISI 316 St.St.) , Ops. Hastelloy Bolt : AISI 316 Stainless Steel , Ops. Hastelloy Palette : AISI 316 Stainless Steel , Ops. Hastelloy T Body : Polypropylene Magnet Case : Polypropylene O-Ring : FPM	: Polypropylene : Polypropylene : Polypropylene : Polypropylene : Polypropylene : Polypropylene : NBR
Fluid	: Water (Oil, gas and aggressive media on request)	: Water (Oil, gas and aggressive media on request)
Tolerance	: ± % 15 of full scale value	: ± % 15 of full scale value
Max. Working Pressure	: 25 bar	: 10 bar
Working Temperature	: (-) 20 °C / (+)110 °C	: (-) 20 °C / (+)70 °C
Ambient Temperature	: (-) 20 °C / (+)70 °C	: (-) 20 °C / (+)70 °C
Contact	: Reed Switch SPST - NO	: Reed Switch SPST - NO
Contact Current	: 1 A	: 1 A
Max. Contact Power	: 10 W / VA	: 10 W / VA
Max. Switching Voltage	: 200 VDC / 140 VAC	: 200 VDC / 140 VAC
Electrical Connection	: ISO 4400 Socket Opt.Cable Output, Socket with LED	: ISO 4400 Socket Opt.Cable Output, Socket with LED
Protection Clas	: IP 65, IP 67 (for sx, cx type) , IP 66, IP 68	: IP 65, IP 67 (for px, bx type)

EFS is used in order to check safely whether there is flow or not by detecting movement of liquids inside the pipe. It provides information about flow with high reliability without spending energy in cooling water or lubricating oil circuits, in the devices such as flash heater, central heating boiler and heater. It should be assembled vertically.

As factory setting, contact is closed when there is flow; contact is open when flow stops. Exact opposite situation can be adjusted by user by changing position of relay in the housing.

Working Principle :

Palette, fastened from one point on the body, moves contact with fluid so that information about flow is obtained. When flow stops, it is provided that paddle comes to first position by pushing magnet with reverse pole in the paddle, attached on the body. By this means, longer life and resistance to higher pressure is provided in comparison with those of spring mechanisms. Reed relay with high precision and long life is used.

Advantages :

High precision , Easy to adjust and assemble , Relay circuit is contactless with fluid.
Low pressure decrease. Economical

Application Areas :

Irrigation systems, low viscosity oil and acids, hot oil lines, heating and cooling systems, water installations.



Conductive Liquid



Low Conductive Liquid

EFS FLOW SWITCHES

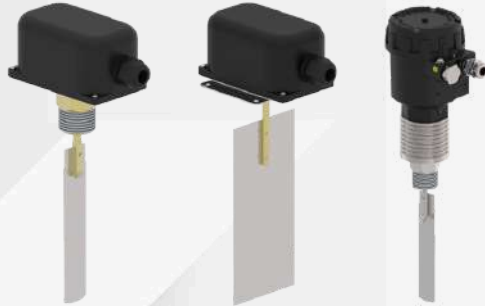

► Technical Specifications

Fluid	: Liquid , Air , Hot Oil
Working Temperature	: (-)20 °C / (+) 90 °C , (-) 20 °C / (+) 85 °C (-)40 °C / (+) 300 °C
Working Pressure	: Max. 10 bar , Max. 5 bar , Max. 20 bar
Paddle Material	: 316 Stainless Steel
Switch Bracket	: Coated Steel , 304 Stainless Steel
Connection Material	: Brass (MS 56) , Chrome Plated Steel , St.St.
Paddle Rod Material	: Brass (MS 56) , Stainless Steel
Housing Material	: PP , Aluminium , Stainless Steel
Bellow Material	: Bronze , Stainless Steel
Seal Material	: NBR , PTFE
Contact	: 1" NPT Male Thread , Hole Flange
Pipe Diameter	: from 1" to 8" - DN 25 to DN 200 (For Liquid) Channels greater than 300 cm ² (For Air)
Connection	: 15 A 250 VAC , NO/NC
Protection Class (EN60529)	: IP 65

Advantages :

- Suitable for hot and cold liquids
- Air tight design
- Can be used in hot oil
- Economical

EFS Flow Switches are used for the monitoring of liquid flow in pipes. When the liquid flow stops or starts its paddle actuates a microswitch (NO/NC) , hereby electrical equipments are protected .The flow switch is suitable to use all kinds of non-corrosive liquid. Flow adjustable via screw mechanism.The products are factory setted. Users can change the adjustment according to application needs.

Applications :

Irrigation systems, low viscosity oil and acids, hot oil lines, heating and cooling systems, water installations.



Conductive Liquid



Low Conductive Liquid

► Technical Specifications

Working Pressure	: 31 bar (450 PSI)
Test Pressure	: 62 bar (900 PSI) %100
Working Temperature	: 4.5 °C - 50 °C (40 °F - 120 °F)
Contact	: 2 x 10 A 125 / 250 VAC 2.5 A 6 / 12 / 24 VDC
Nominal Pipe Size	

Inch	mm	Inch	mm
2	DN 50	1,25 + 0,125 / - 0,62	33,0 ± 2,0
2 1/2	DN 65		
3	DN 80	2.00 ± 0,0125	50,8 ± 2,0
4	DN 100		
5	DN 125		
6	DN 150		
8	DN 200		

Advantages :

- Double contact output.
- Can be connected with U-Bolt.
- Suitable for fire lines.

EFS FLOW SWITCH



► Technical Specifications

Fluid	: Water, Air
Connection Size	: 1/4" BSP, 1/2" BSP , 1" BSP (Std.)
Body Material	: Brass (Nickel Plated) (Std.) Opt. Stainless Steel
Seal Material	: EPDM (Std.) Opt. Viton
Spring Material	: 304 Stainless Steel
Thread Material	: Brass (Std.) Opt. Stainless Steel
Contact Material	: Plastic
Magnet Material	: Alnico
Working Temperature	: 100 °C Opt. 120 °C (Stainless Steel)
Accuracy	: ± % 5 Full Scale
Contact	: 1 x NO 1A / 200 VAC
Max. Working Pressure	: 300 bar
Protection Class	: IP 65

Advantages :

Can be used in hot and cold water / air.
Fully waterproof - air light design.
Economical.
High static pressure.

EFS 71 Flow Switch works with the power of the current in order to monitor the flow with high reliability. Mechanism works with the triggering of the reed switch inside by float while moving in the direction of flow. The reed switch is adjustable from outside of the body. Hysteresis (delay) is the difference in flow between the switch closing and opening again. The difference is the result of the movement required by the float to reclose the open contact. Therefore, shorter the difference; greater the accuracy. Choosing of the right magnets and reed switches; the delay of EFS 71 is adjusted to minimum.

Applications :

Monitoring of cooling circuits in welding machines, compressors, heat exchangers and centrifuges. Monitoring of sealing media for seals and pump dry running, motor cooling systems etc.

EFS THERMAL FLOW SWITCH



► Technical Specifications

Measurement Range	: Water : 0,3...3 m/sec Air : 2...3 m/sec Oil : 0,3...3 m/sec
Accuracy	: ± %1 , ± 0,1 m/s
Setting Time	: 3 min.
Max. Pressure	: 100 bar
Ambient temperature	: (-) 20 °C ... (+) 80 °C
Material of Housing	: PVC
Material of Wetted Parts	: 316 Stainless Steel
Setting	: With potentiometer
Output	: PNP - NO / NC Relay - NO / NC Opt. NPN-NO/NC
Contact Current	: 5A / 250 VAC 30 VDC For Relay Max. 250 mA For PNP or NPN
Power Supply	: 24 VDC (Std.) Opt. 220 VAC
Consumption Current	: <60 mA
Response Time	: 2 (2...10)sec
Max. Temperature Change	: 300 K/min.
Gradient of Medium	
Output Protection	: Reverse, Short, Overload
Electrical connection	: M12 Socket
Protection Class	: IP 67

EFS 81 flow switch used the precision electronic components, reliable and stable circuit design, which are widely used in aerospace, automotive, military and other high-tech fields, make the flow signal is more accurate and stable, at present the products have been widely used in iron and steel, metallurgy, pharmaceutical, chemical industry, etc. EFS 81 flow switch is based on the principle of heat exchange design, probe the built-in heating module as well as the thermal module, heat dissipation of heating module and the flow velocity is closely related to the body. If there is no medium flow in the pipe, thermal circuit receives a fix value, when the fluid flows through the probe, thermal circuit receives the signal changes over medium velocity, thermal circuit will convert the temperature difference signals of heating module and thermal module into electrical signals, the processor will convert into PNP / NPN / RELAY signal output.

Applications :

Gas liquid dual use, it can be used for gas and hydraulic pressure system, circulating water, monitoring of the cutting fluid and lubricant

EFS FLOW SWITCHES



► Technical Specifications

Fluid	: Liquid
Working Temperature	: 0 / (+) 60 °C , (-)20 °C / (+)100 °C
Working Pressure	: (-)30 °C / (+)125 °C
Output	: Max. 10 bar , Max. 20 bar
Connection	: NO Single Contact (Reed Relay)
Cable	: 1/2" BSP Male Thread
Spring and Rove Material	: 0.5 m. PVC
Body Material	: Stainless Steel
Body Colour	: PP , PVC , Stainless Steel
Accuracy	: Blue , Gray
Contact	: Adjustable : 0.7 A 10 W 150 VDC / 120 VAC

Advantages :

Economical.
Relay circuit contactless with fluid.
Easy to install.

EFS is used in order to check safely whether there is flow or not by detecting movement for liquids inside the pipe. It provides information about flow with high reliability with out spending energy in cooling water, in the devices such as flash heater, central heater boiler and heater. It should be assembled vertically.

Applications :

Hot / cold water , steam, compressed air, fuel oil, pharmaceutical and food industry and other fluid lines, food machinery and process lines ...



Conductive
Liquid



Low Conductive
Liquid

EFD FLOW DISPLAY



► Technical Specifications

Body Material	: 304 Stainless Steel Opt. 316 Stainless Steel
Monitoring Material	: Tempered Glass Double Glass
Seal Material	: Klingrid (std) Opt. PTFE or Spiral wound
Pipe Diameter	: DN 15...DN 50 Flange 1/2" BSP... 2" BSP Thread
Max. Working Temperature	: 200 °C Opt. 300°C
Max. Working Pressure	: 16 bar Opt. 40 bar

Advantages :

Complete stainless steel.
Suitable for food.
Easy to install.

EFD is used for monitoring flow in process lines. Must be careful to choose a model which is compatible with liquid characteristics in line. It is available for monitoring from both of side. As optional, flow switch can be assembled in the body. To warrant its vigorously working should be used a filter in the line. Can be manufacturing according to customers need For different pressure range and different mounting types, etc.

ENABAR PITOT TUBE



► Technical Specifications

Fluid	: Liquid, Steam, Gas
Working Temperature	: (-)270 ... (+) 600 °C
Working Pressure	: Max. 100 bar
Body Material	: 316 Stainless Steel
Accuracy	: < %100 Measured Value
Internal Diameter	: DN 50 ... DN 1000

► ENABAR

Advantages :

Economical
Long service intervals
Shorter inflow and outflows sections
Easy to install
Integrated pressure and temperature transmitter

Enabar series pitot tube measures flow in pipes based on the difference pressure principle.

It is a sensitive measuring instrument that can work under difficult conditions.

Applications :

Hot / cold water , steam, compressed air, fuel, water..



Conductive
Liquid



Low Conductive
Liquid

ENVORTEX VORTEX COOLER



► Technical Specifications

Max. Working Pressure	: 7 Bar
Flow Range	: 6 m ³ /hour
Weight	: 500 g.

► ENVORTEX VT1

Advantages :

No electricity
Corrosion resistant stainless steel construction
Small, lightweight
Maintenance free
Cooling temperature can be adjusted
Long life
Quiet operation

It is a cooling apparatus that provides great savings in the long term for cooling the cutting and drilling tools used in the industry. It ensures effective operation of the part in which it is used and also provides profit for the company by using exhausted air carelessly in general. It can produce cold air up to approximately 35 °C or 40 °C.

Applications :

It is used for cooling operating parts of product equipments such as guide, saw, milling cutter, tool bit, and for preparing melt in the cameras, laser cutting machines.

EFO ORIFICE TYPE FLOW MEASUREMENT

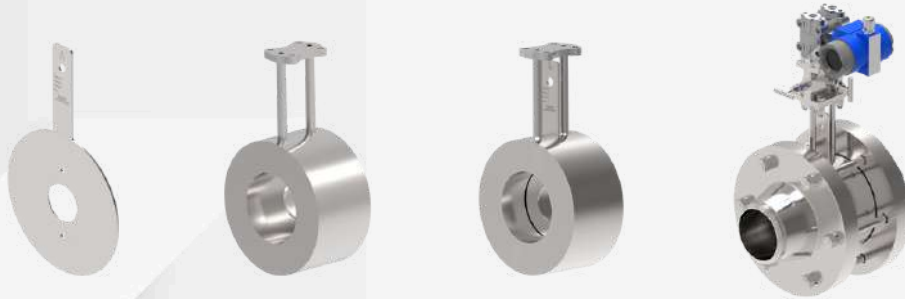

► Technical Specifications

► EFO

Type	: Orifice Plate Compact Orifice Plate- With Flange Compact Orifice Plate - D -D/2 Type Single (monolith) Block Orifice Compact (monolith) Block Orifice Double Block Orifice Compact Double Block Orifice
Plate Material	: 304 Stainless Steel , 316 Stainless Steel
Body Material	: 304 Stainless Steel , 316 Stainless Steel
Gasket Material	: PTFE (Std.)
Bolt, Nut Material	: Carbon Steel , 304 Stainless Steel , 316 St.St.
Flange Material	: Carbon Steel , 304 Stainless Steel , 316 St.St.
Flange standard	: EN 1092-1, ANSI B16.5
Pipe Dimension	: DN 50.... DN 400 mm
Pressure Class	: PN 10 / 16 / 25 / 40 / 64 , 150 lbs / 300 lbs / 600 lbs
Temperature	: (-)100 °C...(+) 500 °C
Fluid	: Fluid, Steam, Gas
Marking	: Flow up (+) face

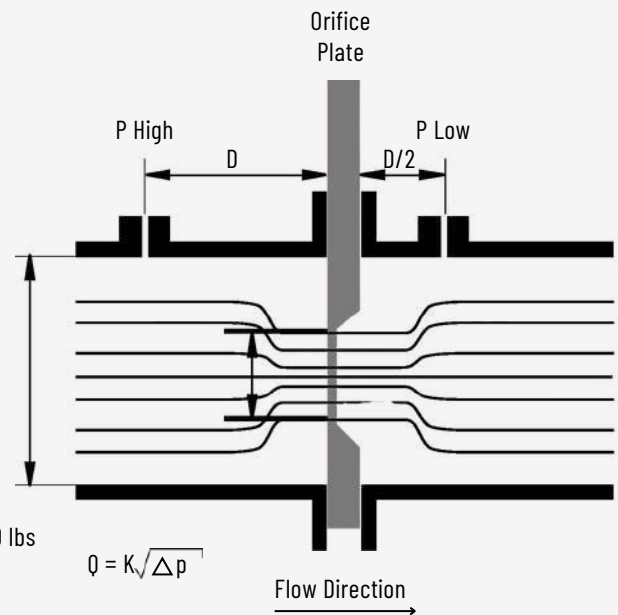

$\Delta P = P \text{ High} - P \text{ Low}$
 Q : Flow
 K : Correction Factor

Advantages :

- Can be used in liquids and gases
- No moving parts
- Low risk of malfunction
- Low Cost

In industrial facilities, different types of flow measurement devices are being used, and each measuring method have advantages to each other, which depends on where they are being used. EFO model orifice plates are the most frequent method for flow measurement.

It works according to Bernoulli theorem.

Volume value of a flow inside a constant space in a pipe, equals to square root of differential pressure value created by orifice plate inside that pipe. It is mounted on where flow is laminar.

A flat stainless-steel metal plate is drilled as calculated holes therefore the pressure difference between inflow and outflow can be calculated.

Options are available for measure of the holes and type of the flow.

Accuracy of measurement is affected by production measures and quality, mounting conditions and type of the liquid.

Model EFO offers economic and easy mounting solution for variety of liquid types. Model EFO produced in EN ISO 5167 standards.

EFM ELECTRO MAGNETIC FLOWMETER



► Technical Specifications

Fluid	: Liquids
Flow Range	: 0,0045 m ³ to 113094 m ³
Pipe Diameter	: DN 10 ... DN 2400 mm
Speed Measure Interval	: 0.1 m/sec to 10 m/sec
Body Material	: Aluminium Alloy, : Opt. 304 Stainless Steel , 316 Stainless Steel
Sensor Material	: 316 Stainless Steel : Opt. Hastelloy C, Hastelloy B, Titanium, Tantalum
Wet Part Material	: PTFE or Rubber
Temperature Interval	: (-) 20 °C / (+)150 °C PTFE ; : (-) 20 °C / (+) 60 °C Rubber
Sensitivity	: 0.2 % High Sensitivity
Humidity Interval	: 5 - 95 % RH
Minimum Conductivity	: 20 µS
Connection	: Flange Connection
Supply	: 85...265 VAC or 24 VDC
Protection Class	: IP 67 Opt. IP 68
Output	Pulse, Analog, RS 485, Relay
Sample Interval	0.2 secs to 100 secs Daily
Record	Weekly, Monthly, Annually Total

► EFM

Electro-magnetic flowmeters are commonly preferred in flow measure of conductive liquids. Electro-magnetic flowmeters returns volumetric values as L/sec. , L/min. , L/h. , m³/sec., m³/min., m³/h. Electromagnetic method is based on Faraday's Law of Induction. Due to following aspects, electromagnetic flowmeters are

Advantages:

Not-including moving part, wet part's material are optional for different liquids, no pressure loss, showing excellent performance. Electromagnetic flowmeters outputs current flow and total flow thus; with the help of electrical signals returns data of flow to the system.

Applications :

Treatment Plants, Chemical, Petrochemical Industry, Food Sector, Textile Industry, Paper Production Sector, Power Plants, Water Distribution Networks Agricultural irrigation sector.

Advantages :

Tft Display
The Units Can Be Selected On The Display.
Simulation Properties

ESD100 Series, is the universal input is suitable for many measuring sensors. (Panel type pressure,temperature, level and flow display)Thanks to TFT display it can be easily read in dark or sunny environments. The selected units can be seen on the display. Device has standard communication output which can be also simulated.

► Technical Specifications

Input (Selectable)	: 4-20 mA, 0-10 VDC, 0-5 VDC, Puls (PNP,NPN,Push-Pull,Reed)
Output (Selectable)	: 4-20 mA , 0-10VDC ve Puls (push-pull)
Communication	: Modbus RTU-RS485
Analog Input Resolution	: 10 bit
Digital Input Speed	: Max.10 KHz
Digital Output Speed	: Max. 50 Hz
Indicator	: 4.3" 480 mm x 272 mm pixel resistive touchscreen
Working Humidity	: % 10...% 85 (Non-condensate)
Power Supply	: 24 VDC, ±%10
Power consumption	: 3 W
Dimensions	: 144 mm x 144 mm (Front) , 134 mm x 134 mm (Rear) , Depth 100 mm
Protection Class	: IP 65 (Front)

► SMART CONTROL DEVICE



Conductive Liquid

EF FLOWMETER

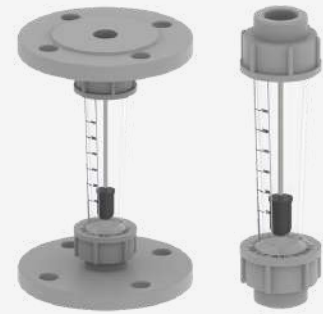

► Tech. Specifications

► EF

Measuring tube	: Borosilicate Glass
Tube Length	: 100 mm
Protection Class	: Polycarbonate
Float Stop Material	: PTFE
Float Material	: 316 Stainless Steel
Seal Material	: Viton
Max. Working Pres.	: 16 Bar
Max. Working Temp.	: 100 °C
Connections (R)	: 1/4" BSP or M10 x 1mm
Needle Valve	: 316 Stainless Steel
Accuracy	: Class 2.5
Weight	: 600 g.

It is designed to be adjustable precisely for small flow. It is an economical flowmeter as well as it enables comfortable following and adjusting offlow with its compact structure.

Advantages :

- Wetted parts are stainless steel
- With needle valve
- Accurate flow setting

Areas of Application :

Water, air, various gases.



Conductive Liquid



Low Conductive Liquid

► Tech. Specifications

► EF

Fluid	: Water, Air Special fluids should be stated
Max. Working Press.	: 7...15 bar
Max. Working Temp.	: 150 °C
Measuring Tube	: Borosilicate Glass
Float Material	: 316 Stainless steel
Float Stop Material	: PTFE
Connections	: 316 Stainless steel
Housing	: Coated Steel
Accuracy	: +/- %1 t.s.

Float which moves freely without friction in the measuring tube, changes location by being pushed by fluid. This changing flow rate depends on weight of float an density and viscosity of fluid. Pressure olecease remains area by rasing flow rates so asto depend on increasing flow area by rasing flow rate and speed of fluid. It should be assembled vertically.

Advantages :

- Wetted parts are stainless steel
- Accurate flow setting

► Tech. Specifications

► EF

Fluid	: Water or Air
Max. Working Press.	: 10 bar
Max. working Temp.	: 70 °C
Measuring Tube	: Trogamid
Float Material	: PVDF
Guide Material	: 316 Stainless Steel
O-Ring Material	: Viton
Connections	: Thread
Accuracy	: ± % 3 t.s.

Float which moves freely without friction in the measuring tube, changes location by being pushed by fluid. This changing flow rate depends on weight of float an density and viscosity of fluid. Pressure olecease remains area by rasing flow rates so asto depend on increasing flow area by rasing flow rate and speed of fluid. It should be assembled vertically.

Advantages :

- Easy monitoring
- Contact can be mounted

EF TURBINE FLOWMETER
EF MINI TURBINE FLOWMETER



► Technical Specifications

► EF 24

► EF 34 / 54

► EF 100

Fluid	: Liquid	: Liquid	: Liquid
Working Temp.	: -10/+85 C	: -10/+85 C	: 0/+80 C
Max. Pressure	: 10 bar	: 10 bar	: 10 bar
Range	: 2...40 l/min	: 3...150 l/min 7...400 l/min	: 0,15...8m/sec.
Output	: 1070 Puls/l (NPN)	: 1070 Puls/l (NPN)	: Puls (NPN)
Accuracy	: +/- %1	: +/- %2 , %3	: +/- %2
Connections	: 3/4" BSP Male	: 1 1/4" BSP Male, 2" BSP Male	: 1 1/4" BSP Male (DN 15 ...100)
Cable	: PVC 2 m.	: PVC 2 m.	: PVC 0.2 m.
Wetted Parts	: ABS	: ABS	: ABS
Protection	: IP 68	: IP 68	: IP 68
Power Supply	: 4,5 ... 24 VDC	: 4,5 ... 24 VDC	: 4,5 ... 24 VDC

It's designed for low flow measuring and monitoring. With the compact form it ensures high accurate flow measurement and control. Cable and high precision pulse sensor placed into the body provides to get accurate values in the long time.

Areas of Application :

Smart drinking Fountains , beverage industry , tes and coffee machine , water purifier , liquid filling machines...

Advantages :

Economical.
Easy to assemble.
Easy to adjust.



Conductive Liquid

► Technical Specifications

► EF 06

Fluid	: Liquid
Working Temp.	: -25/+120 C
Max. Pressure	: 10 bar
Range	: 0,05...15 l/min (5 Flow Ranges)
Accuracy	: +/- %1
Connections	: Ø6mm. Hose
Output	: (NPN / PNP) Pulse/1



Areas of Application :

Beverage industry, dosing app. ...

Advantages :

Economical.
High Accuracy.

EPS PRESSURE / DIFFERENTIAL PRESSURE SWITCH

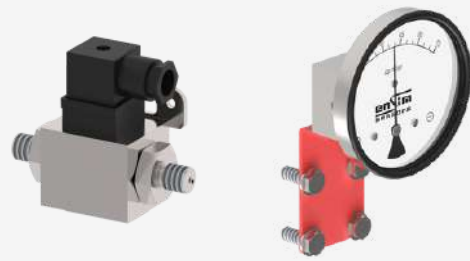
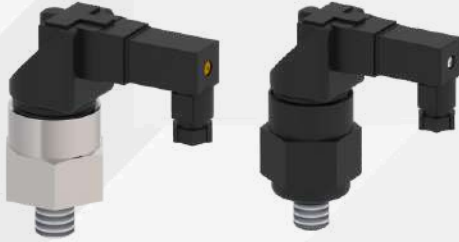

► Technical Specifications

Body materials	: 316 St.St., PP
Range	: 0...(+)1 bar / 3.5 bar / 5 bar / 10 bar 20 bar / 100 bar / 200 bar / 400 bar (-) 0.8 bar ... (-) 01 bar
Diaphragm	: NBR, Stainless Steel , Viton
Plastic Parts	: PP
O-Ring	: NBR
Mechanical Connections	: 1/4" BSP. , 1/2" BSP
Max.Pressure	: x 1.5
Max. Current	: 5 A / 250 VAC
Contact	: 1 x NO / NC
Working Life	: 10.000.000 times (Depends on working range)
Working Temperature	: (-) 40 °C...(+) 150 °C , (-) 25 °C...(+) 60 °C
Relative Humidity	: 5-95 % RH
Protection Class (EN60529)	: IP 65

► EPS

Advantages :

High reliable accuracy
Easy adjustable
Economical

Inside the body , there are a compressed spring and a diaphragm. The spring and diaphragm move with pressure and trigger the contact and give pressure information. When the pressure is come down to adjusted pressure value , the contact is turn back to former position.

High precision and durable contact is used.

The EPS Pressure Switch is used for inline pressure measurement and control. The ideal type of assembly is vertical.

Application Areas :

It provides pressure information at high reliability without consuming energy in cooling water or lubricating oil circuits in devices such as water heater, combi boiler, heater. Filters, level measurement, backflow systems.

► Technical Specifications

Model	: EPS200
Diff. Pressure Range	: 0,3 bar... 3 bar
Display	: Not available
Repeatability	: ± % 2 , at 20 °C
Average Dead Band	: 0.25 bar until 1.5 bar 0.8 bar until 1.5 bar
Max. Pressure	: 35 bar
Contact	: 1 x NO/NC , 3 A / 250 VAC
Electrical Connection	: DIN 43650 A Socket
Mechanical Connection	: 1/4 " BSP Std
Working Temperature	: (-) 20 °C....(+) 80 °C Ops.(-) 40 °C...(+)120 °C
Body Material	: Aluminium
Diaphragm Material	: Buna-N, Opt. Viton
Connection	: Steel Opt. Stainless Steel
Spring	: Stainless Steel
Protection Class (EN60529)	: IP 65
Weight	: 0,5 kg

► EPS 200

► EPS 500

Model	: EPS500
Diff. Pressure Range	: 0,5 bar ... 4 bar
Display	: Available
Repeatability	: ± % 2 , at 20 °C
Average Dead Band	: 0.25 bar until 1.5 bar 0.8 bar until 1.5 bar
Max. Pressure	: 10 bar
Contact	: 1 x NO/NC , 3 A / 250 VAC
Electrical Connection	: DIN 43650 A Socket
Mechanical Connection	: 8 mm Hose
Working Temperature	: (-) 20 °C....(+) 80 °C Ops.(-) 40 °C...(+)120 °C
Body Material	: Stainless Steel
Diaphragm Material	: Buna-N, Opt. Viton
Connection	: Stainless Steel
Spring	: Stainless Steel
Protection Class (EN60529)	: IP 65
Weight	: 1,25 kg



EPS OEM PRESSURE SWITCH



► Technical Specifications

Type
Working Principle
Size range

Static Pressure
Working Temperature
Mechanical Connection
Connection Material
Output
Contact Sensitivity
Contact Life
Protection Class (EN60529)

► EPS...h

: Hydraulic
: With Piston , Adjustable
: 50 - 350 bar

: Max. 500 bar
: (-)20 °C... (+) 100 °C
: 1/4" BSP Female (Std.)
: Aluminum Casting
: 2 A NO / NC - 42 / 220 VAC
: < % 3
: 500000 times
: IP 65

► EPS...c

High Pressure
With Piston , Stationary
50 - 150 bar
50 - 200 bar

Max. 500 bar
(-)20 °C... (+) 100 °C
1/4" BSP , 1/8" BSP (Std.)
Steel-Nickel Coated Opt. Brass. St.St.
2 A NO / NC - 42 / 220 VAC
< % 5
1000000 times
IP 65

► EPS...c

Low Pressure
With Membrane , Stationary
1 - 5 bar
1 - 10 bar
10 - 20 bar
20 - 50 bar
Max. 300 bar
(-)20 °C... (+) 100 °C
1/4" BSP , 1/8" BSP (Std.)
Steel-Nickel Coated Opt. Brass. St.St.
2 A NO / NC - 42 / 220 VAC
< % 5
1000000 times
IP 65



► Technical Specifications

Type
Working Principle
Size range

Static Pressure
Working Temperature
Mechanical Connection
Connection Material
Output
Contact Sensitivity
Contact Life
Protection Class (EN60529)

► EPS...v

: Vacuum
: With Membrane , Stationary
: (-)200 mbar ... (-)800 mbar

: Max. 20 bar
: (-)20 °C... (+) 100 °C
: 1/4" (Std.) BSP
: Steel-Nickel Coated Opt. Brass. St.St.
: 2 A NO or NC - 42 / 220 VAC
: < % 5
: 1000000 times
: IP 65

► EPS...m

Mini
With Membrane , Stationary
0,1 - 1 bar , 0,5 - 5 bar
1 - 10 bar , 10 - 20 bar
20 - 50 bar 50 - 100 bar
Max. 300 bar Max. 500 bar
(-)20 °C... (+) 100 °C
1/4" BSP , 1/8" BSP (Std.)
Steel-Nickel Coated Opt. Brass. St.St.
2 A NO or NC - 42 / 220 VAC
< % 5
1000000 times
IP 65

Advantages :

Small size
Long life
Easily adjustable and mounted
Economical

EPS PRESSURE SWITCH

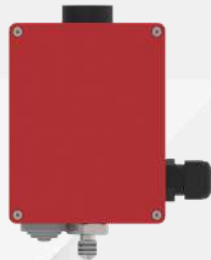

► Technical Specifications

► EPS

Contact Pressure	: 3 bar (when it falls) It can be manufactured upon request
Max. Working pressure	: 200 bar
Test Pressure	: 300 bar
Contact	: 2 x 10A NO / NC - 250VAC
Housing Protection Class	: IP 54
Red Color Protection Button	: (Above)
Test Button	: (Below)
Connection	: 1/4" BSP (Std.) Ops. Can be manufactured upon request
Housing Material	: Aluminium
Working Temperature	: (-) 20 / (+) 50 °C
Process Connection Material	: 304 Stainless Steel (Std.)
Electrical Connection Material	: PG 11 Plastic

EPS 300 Model pressure switch is designed for wet or dry pipe systems with alarm check-valves preaction or deluge valves; in such special designs with automatic fire sprinkler systems to be used for detecting water flow. It is also used in low pressure control, between 3-15 PSI (0 - 10bar) adjustable.

Advantages :

Test button is available.
There is an arming button.
Max. working pressure.
It is easy to commission.

Applications :

Fire pipelinecontrol systems, liquid pipelines that needs pressure regulation.

► Technical Specifications

► EPS 1000

Thread Material	: Polyamide Fiber
Housing Material	: Polyamide Fiber
Diaphragm Material	: Viton
Contact	: 10A-125 / 250 VAC 2,5A-24VDC
Output	: 1 or 2 Relay NO/NC
Connection	: 1/2" BSP Male Thread (Std.)
Dimensions	: 85x102x123 mm
Measure Area	: 0-10 bar (std.) Opt.
Working Temperature	: (-)10...(+)60 °C
Default Setting	: 0,2 - 1,0 bar (3-15 PSI)
Max. Working pressure	: 21 bar (300 PSI)
Differential	: 0,21 bar (3 PSI)
Protection Class	: IP 66
Weight	: 290 g.

EPS Model pressure switch is designed for wet or dry pipe systems with alarm check-valves preaction or deluge valves; in such special designs with automatic fire sprinkler systems to be used for detecting water flow. It is also used in low pressure control, between 3-15 PSI (0,2-1 bar) adjustable.

Advantages :

Economical.
Set value can be adjusted..

Applications :

Fire pipelinecontrol systems, liquid pipelines that needs pressure regulation.



Conductive Liquid



Low Conductive Liquid



ELX COOLING APPARATUS



► Technical Specifications

Material	: ST 37 Steel, 304 Stainless Steel 316 Stainless Steel
Max. Working Pressure	: 16 bar , 30 bar
Working Temperature	: 250 °C
Total Length	: 180 mm , 240 mm , 290 mm
Process Connection	: 1/4" BSP, 1/2" BSP Female ,1/2" BSP Male
Sensor Connection	: 1/4" BSP, 1/2" BSP Female , 1/2" BSP Male

► SIPHON



► THERMOWELL

Material	: 304 Stainless Steel Opt. 316 Stainless Steel
Max. Working Pressure	: 16 bar (Std.) Opt. 30 bar
Working Temperature	: 250 °C (Std.) 600 °C
Total Length	: According to the order
Process Connection	: It is selected from the table
Sensor Connection	: It is selected from the table



► Technical Specifications

Material	: 304 Stainless Steel Opt. 316 St.St.
Max. Working Pressure	: 30 bar
Working Temperature	: 1200 °C / 800 °C / 400 °C
Total Length	: 200 mm / 150 mm / 100 mm
Process Connection	: 1/4" BSP, 1/2" BSP Female
Sensor Connection	: 1/4" BSP, 1/2" BSP Female

► CAPILLARY COOLER



► COOLER

Material	: 316 Stainless Steel
Max. Working Pressure	: 80 bar
Working Temperature	: 180 °C / 250 °C
Total Length	: 87 mm /107 mm
Process Connection	: 1/2" BSP
Sensor Connection	: 1/2" BSP , 1/4" BSP



► Technical Specifications

Max. Working Pressure	: 25 bar Opt. 50 bar
Max. Working Temperature	: 238 °C
Body	: 304 Stainless Steel Opt. 316 St.St.
Serpentine	: Copper Pipe Opt. 316 Stainless Steel
Cooler Liquid Input-output conn.	: 1/4" BSP
Max. Body Pressure	: 10 bar Opt. 50 bar
Elbow Material	: 304 Stainless Steel Opt. 316 Stainless Steel
Volume	: 2 L.

► SAMPING VESSEL



► CONDENSATION TANK

Material	: 316 Stainless Steel
Test Pressure	: 155 bar
Connection	: 3 x 1/2" BSP



► Technical Specifications

Material Thickness	: 0,15 ... 2 mm
Diameter	: 6 ... 80 mm
Length	: Up to 900 mm
Material	: 316 St. St. , Bronze

► ENBELLOW



Conductive
Liquid



Low Conductive
Liquid

ELX INSTRUMENT VALVE

Needle valves are designed especially for corrosive and dangerous environments. These valves can be used in the process control, instrumentation and flow control application. It is designed with maximum efficiency in order to provide high quality and low cost in various liquid and gas control system.

Test pressure : x 1,5

Standard;

Design: ASME B16.34

Wall Thickness: ASME B16.34

Pipe Thread: ASME B1.20.1.B521

DIN 2999 / 259 , ISO228/1 , JIS.B 0203 , ISO7/1

Inspection & Testing: M55 SP-110, EN12266

Advantages:

Complete Stainless Steel

Weldness Single Part Body

Max. 690 bar

Max. 400 °C

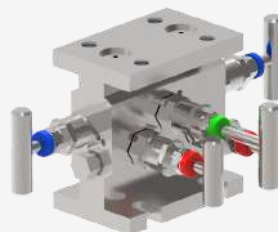
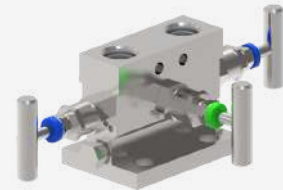
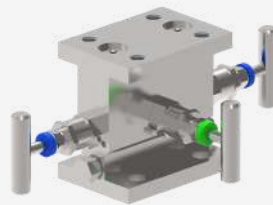

Conductive
Liquid



Low Conductive
Liquid



ETT TEMPERATURE SENSOR AND TRANSMITTER



► Technical Specifications

Type
Range
Mechanical Connection
Electrical Connection
Sensor
Output
Supply
Supply Material
Stem Length
Protection Class (EN60529)
Pipe Diameter

► ETT

: Line and wall
: (-)200 °C...(+)800 °C
: 1/2" BSP (Std) (Depends on request.)
: Socket (ISO 4400) , Terminals, With Cable
: 1 x pt100 3 Wires Cable (Class B - EN 60751)
(Class A - EN 60751)
: 1 or 2 x Pt 100
2 Wires 4-20 mA (Std.)
3 Wires 4-20 mA, 0-20 mA
0-5 V,1-5 V, 0-10 V
: 10 - 30 VDC
: St.St. , PTFE , Aluminium , Plastic
: Min. 10 mm Max. 10m. - On Request
: IP 65 , IP 66 , IP 68
: Ø 6 , Ø 8 , Ø 10 , Ø 11 , Ø 14 mm On Request

► DX-ETT

: Line and wall
: (-)20 °C...(+)395 °C
: 1/2" BSP (Std) (Depends on request.)
: Socket (ISO 4400) , Terminals, With Cable
: 1 x pt100 3 Wires Cable (Class B - EN 60751)
(Class A - EN 60751)
: 1 or 2 x Pt 100
2 Wires 4-20 mA (Std.)
3 Wires 4-20 mA, 0-20 mA
0-5 V,1-5 V, 0-10 V
: 10 - 30 VDC
: St.St. , PTFE , Aluminium , Plastic
: Min. 10 mm Max. 10m. - On Request
: IP 65 , IP 66 , IP 68
: Ø 6 , Ø 8 , Ø 10 , Ø 11 , Ø 14 mm On Request

Resistance thermometers are used in the locations where precise temperature measurement is demanded in the industry. It is based on change of electrical resistance of conductor subject to the temperature. It is used the resistance detector that is wound from thin platinum or nickel wire insulated within enamel, glass or ceramic as conductor. Detector provides 100 ohm resistance output in 0°C.

Increasing or decreasing values of resistance subject to temperature are measured and then, temperature is detected.

Copper, silver or nickel-chromium connection wires are added into two ends of resistance detector. It can be used from -200°C to +850°C.

Analogue output information is taken through pt100 sensors in compliance with EN60751 and then, assessed in the automation system.

In order that resistance thermometers can measure accurately, it is recommended that it has dipping length as much as 6 and 15 times of dipping diameter.

Copper or Silver wire is used up to 500 °C and Nickel chromium is used after 550 °C between Pt 100 and connector. Copper conducting wire is used between device and pt100. It should have 2 wires up to 10 m., 3 wires up to 150 m. and 4 wires after 150 m.

Advantages :

Models up to max. of 600 bar
Practical and economical
Digital display can be mounted

Areas of Application :

Machines, tank, boilers, gas and liquid fluid,
surface temp. measurement,
ambient temperature measurement.



Conductive Liquid



Low Conductive Liquid



Solids Particulate Material



Adhesive and Acid / Basic Liquid



EPH PH SENSOR PH CONTROL DEVICE

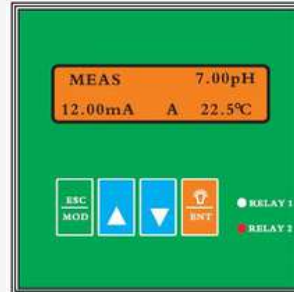
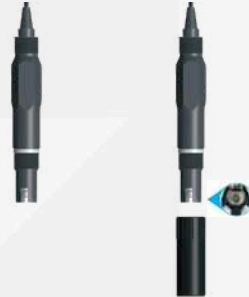

► Technical Specifications

► EPH

PH	Measure Range	: -2.00 ~ 16.00 pH
	Resolution	: 0.01 pH
	Accuracy	: ± 0.01 pH
	Input Impedance	: $3 \cdot 10^{12}$ W
ORP	Measure Range	: -2000 ~ 2000mV
	Resolution	: 0.01 mV
	Accuracy	: ±1 mV
Temperature	Measure Range	: -25 ~ 130 °C
	Resolution	: 0.01 pH
	Sensor	: PT1000
Signal Output	Compensation	: Automatic / Manual
	PH / ORP	: 4-20 mA (Adjustable)
	Current Accuracy	: 1 % FS
Relay Output	Load	: < 750 W
	On / Off	: 2 SPST Relays
	Load	: 5A 250VAC / 5A 30 VDC
Data interface		: RS485 For (EPH-Ci)
		: Compatible With standard MODBUS-RTU
	Power	: 100 ~ 240 or 24VDC
	Working Tem.	: 0 ~ 60 °C
	Humidity	: < 90 %
	Protection Class	: IP 55
	Installation	: Panel Mounting
	Dimensions	: 96x96x138 mm (H*W*D)
	Weight	: 0.5 kg

Advantages:

LCD display with backlight, English operation interface. Calibration and setting can set cryptoguard. Technical parameters can be set with buttons on site. High stability, high accuracy, can measure PH, ORP and temperature. Temperature compensation. Multiple output (2 relays, 4-20mA, RS485). Supper anti-interference design can be used for strong interference with field operations and anti-electromagnetic interference. The built-in memory chip ensures that the parameters and calibration data are not lost when shut down or off normally. Can automatically detect the temperature probe and enter the automatic temperature compensation program.

Application :

Soilless cultivation, aquaculture, water treatment, thermal power, metallurgy, pharmaceutical, enviromental protection, food, tap water, chemical industry etc.

Ensim water quality analysis instrumentation hardware used the precision electronic components, strong anti-interference and reliable stable patent integrated circuit design, which are widely used in aerospace, automotive, military and high-tech fields, simple operation and rich interface software instrumentation system, make the detection signal is more accurate and stable, the current products have been widely used in metallurgy, electronic power, pharmaceutical, chemical, oil, water treatment, food and other industries.



EBQ GSM CONTROL MONITORING AND TRACKING



GSM RELAY CONTROL AND WARNING DEVICE



GSM RELAY CONTROL AND WARNING DEVICE



► **Technical Specifications**

► **EBQ**

Model	: EBQ100
Power Need	: 2 VDC 1.5 A
Relay Output	: 8 Panasonic Relay (5 A 277 VAC / 3 A 30 VDC)
Inputs	: 4 (Dry Contact)
LCD	: 2 x 16 LCD
Buzzer	: Yes
Call Notification	: 10 Number
SMS Notification	: 10 Number
Email Notification	: 3 Mail Address (No SSL, May be accepted as spam from servers)
Antenna	: SMA Connector (3 m. GSM Antenna included)
Terminal	: Plug-in Terminal (3.81 mm)
Enclosure	: Rail Type Plastic Enclosure : Also suitable for wall mounth 157 mm x 90 mm x 60 mm

► **Technical Specifications**

► **EBQ**

Model	: EBQ103
Power Need	: 2 VDC 1.5 A
Relay Output	: 2 Panasonic Relay (5 A 277 VAC / 3 A 30 VDC)
Inputs	: 3 (Relay Contact)
Analog Sensor	: 2 Analog Input (1 x 4-20 mA, 1x 10K NTC Temperature Sensor Input)
Buzzer	: No
Call Notification	: 10 Number
SMS Notification	: 10 Number
Email Notification	: 10 Mail Address
Antenna	: SMA Connector (3 m. GSM Antenna included)
Terminal	: Plug-in Terminal (3.81 mm)
Enclosure	: Rail Type Plastic Enclosure : Also suitable for wall mounth 110 mm x 90 mm x 60 mm

GSM RELAY CONTROL AND WARNING DEVICE

► **Technical Specifications**

► **EBQ**

Model	: EBQ119
Power Need	: 12 - 24 VDC 1 A
Relay Output	: Max 24 Relay with external device (With EBQ352 or EBQ351-19 device)
Dry Contact Input	: Max 24 Input with external device (With EBQ360 or EBQ51-19 device)
Modbus Register	: 8 Modbus Register
Alarm	: 20 Modbus Alarm , 40 Digital Input Alarm
Communication	: RS 232 (For device Settings) RS 485 (Form Modbus Registers)
Buzzer	: Yes
Alarm Notification	: 10 Number for SMS Notification 10 Number for Silent Call : 3 Email Address for Mail Notification SMA
Antenna	: Connector (Antenna Included)



SMS ASSISTANT

SMS Asistan Application makes easy to adjust the settings or to control the all GSM control units. We have both Android and IOS versions. You can add many devices to the software and control them individually. You can add many macros for frequently used settings or control commands.

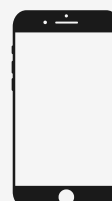



EBQ INDUSTRIAL AUTOMATION PRODUCTS



► Technical Specifications

Model	: EBQ370-02 EBQ370-02N
Power Need	: 24 VDC
Input	: 6 x 4-20 mA Sensor Input
ADC	: 16 Bit 12 Bit
Protocol	: Modbus RTU
Terminal	: Screw Terminal (5.08 mm)
Enclosure	: Rail Type Enclosure 70 mm x 90 mm x 60 mm

► EBQ



► Technical Specifications

Model	: EBQ420
Power	: 24 VDC
Requirements	: GPRS / TCP Ethernet
Internet Access	: 4 Pcs. Relay
Number of Relays	: 1 Pcs.12C Temperature humidity sensor
Sensors	4 Pcs. 4,-20 mA sensor 4 Pcs. Digital Input 10 Pcs. RS 485 Mudbus Register
Terminals Type	: Plug-in Terminals (3.81 mm)
Box	: 157 mm x 90 mm x 60 mm

► EBQ



► Technical Specifications

Model	: EBQ485
Voltage Isolation	: 1000 V
USB Connector	: USB A Type Male
RS485 Connector	: Plug-in Terminals (3.81 mm)
Dimensions	: 50 mm x 30 mm x 15 mm

► EBQ

Technical Specifications

Model	: EBQ113
Power Need	: 12 VDC 1.5 A
Relay Output	: 2 Panasonic Relay
Digital Inputs	: Max. 3 level switch
Level Sensor	: 4-20 mA Level Sensor
Temperature Sensor	: 10K NTC Input
Enclosure	: Plastic Rail Type 110 mm x 90 mm x 60 mm

► EBQ

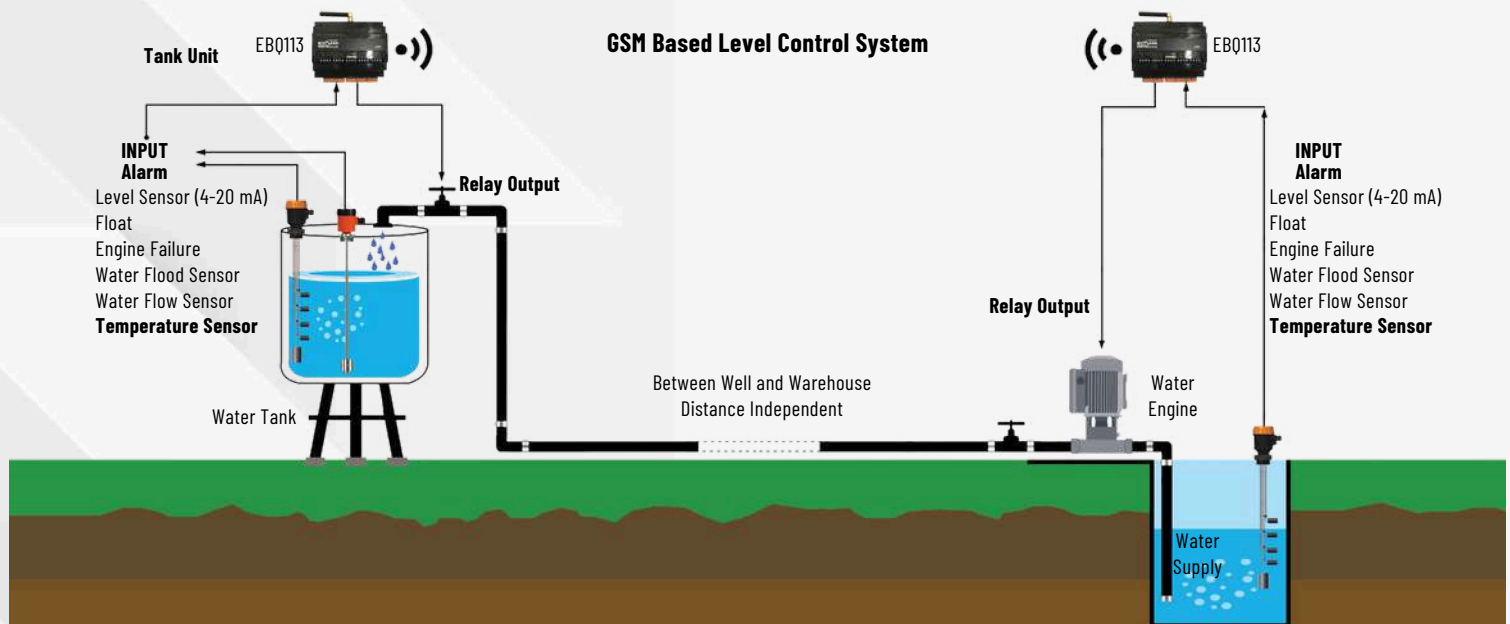

ENSIM SCADA



Basic Scada is a program that, easy to use and based on windows operation system. Thanks to this program, you can connect devices from modbus RTU and modbus TCP protocol to read and save the data. Also this program gives you opportunity to control connected devices.

Recorded data can be reported, analysed and shown on graphics. More over this program can produce new virtual parameters with data that read by using mathematical calculations .For example ; You can calculate volume of a tank with using its height, or you can calculate its dew point value with using temperature and humidity information.Due to usage of network based database, data collector programs can be run more than one at different locations from eachother. Also, you can access analyse programs on other computer by using network to get reports.Program can upload the data on our industrial cloud system or create alarm records by your definitions.

ensim live INDUSTRIAL CLOUD

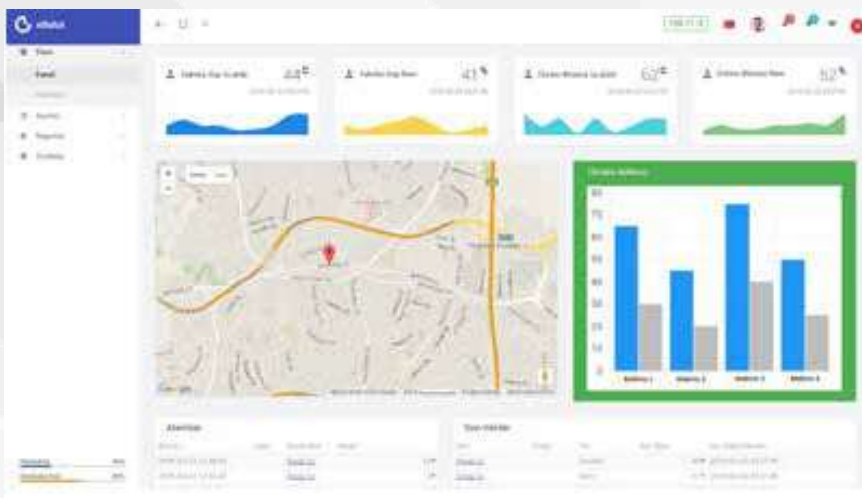

Industrial cloud system is a system that can save data from devices to its own memory for tracking and reporting.Also it can inform its users in critical conditions by creating alarm. You can export you data from PLC and Scada systems to cloud and track them from your phone or tablet device.

You can fastly access important devices data without using web interface by using E-Cloud application which can be downloaded from Apple and Adroid market. You can identify alarm criterias on system parameters to get calls,sms or e- mails in those alarm situations, or get push notifications from mobil devices with "1Industrial Cloud Alarm" 1d. Also it is possible to create virtual parameters on system. For example ; You can calculate volume of a tank with using its height, or you can calculate its dew point value with using temperature and humidity information to show as its natural parameter to system. Panel screens can be customized due to usage and you can identify different authority to users. You can view saved data on devices to create reports or graphics.

SALES OFFICE



PRODUCT LINE





QUALITY CONTROL



www.ensim.com.tr

LONCA MAK. SAN. TİC. A.Ş.

 Ferhatpaşa Mah. Gazipaşa Cad. No:104A
Ataşehir / İSTANBUL - TÜRKİYE 34888
 Phone:+90 216 505 05 55 / Fax: 216 515 45 84
 www.ensim.com.tr / lonca@ensim.com.tr

 LOCATION



 WEB

